

# FURUNO

## SERVICE MANUAL

### NAVTEX RECEIVER

MODEL NX-700A/B

**Important;**

This manual is intended for use by authorized FURUNO service technicians for the installation of this equipment.

Under no circumstances should the contents of this manual be released to the user.



**FURUNO ELECTRIC CO., LTD.**  
NISHINOMIYA, JAPAN

PRINTED IN JAPAN

**ECF**

(Elemental Chlorine Free)

The paper used in this manual  
is elemental chlorine free.

© **FURUNO ELECTRIC CO., LTD.**

9-52 Ashihara-cho,  
Nishinomiya 662-8580, JAPAN

Telephone : 0798-65-2111

Fax : 0798-65-4200

FURUNO Authorized Distributor/Dealer

All rights reserved. Printed in Japan

Pub. No. SME-56490-A1

( NAYO ) NX-700A/B

FIRST EDITION : DEC. 2005

A1 : AUG. 10, 2006



\*00015767700\*



\*SME56490A10\*

# Information

Issued by: **FURUNO ELECTRIC CO., LTD**  
**SERVICE MANAGEMENT & COMMANDING DEPARTMENT**

APPROVED BY *[Signature]*  
 WRITTEN BY *[Signature]*

Addenda No.1 to NX-700A/B Service Manual, Pub. No. SME-56490

## NX-700A/B

### Change Alarm Output to Normal Close

The logic of alarm output is changed from the normal open to the normal close. The corresponding CPU board is 08P3225-33 and after. When changing from the normal open to the normal close, exchange NX-700B (Unit without a printer). Not exchange CPU board.

U17: G3VM61E -> PS7241\_1B  
 (Normal Open) -> (Normal Close)

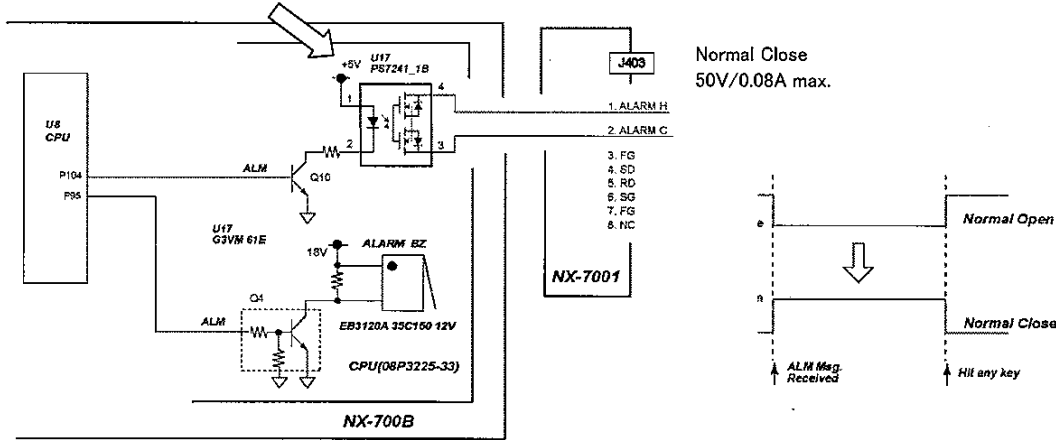

⑤

SSB

**Other Setting) System -> Warn Msg Alm**

This is for alarm sound setup when receiving "Warning message: A, B, L". The ON/OFF setup for the external alarm signal output works with this setup. Then, irrespective of this setup, alarm sound and external alarm signal are outputted when receiving "SAR message: D".

**Factory-modified sets**

From the production in September 2006 and after

This page is intentionally left blank.

## Setting and Checking Guide

### Chapter 1. Overview

1.1 Overview .....	1-1
1.1.1 Configuration .....	1-1
1.1.2 Installation .....	1-3
1.2 Operation Guide .....	1-4
1.2.1 NAVTEX system .....	1-4
1.2.2 Auto mode: Automatic station selecting function .....	1-6
1.2.3 Saving of NAVTEX message .....	1-7
1.2.4 Operation Guide .....	1-8
1. Status display .....	1-8
2. User display .....	1-10

### Chapter 2. System Setting

Overview .....	2-1
1. To call up the Initialize menu .....	2-1
2. Program .....	2-1
3. Setup Guide .....	2-2
2.1 Nav data .....	2-5
2.1.1 Setup of Nav data input .....	2-6
2.2 Setting of NAVTEX menu .....	2-8
2.2.1 Program Ver-02.01 .....	2-8
1. Mask Mode .....	2-8
2. Auto Rcv Mask .....	2-9
3. Local Channel .....	2-10
4. Rcv Mask .....	2-10
5. INS Output Mask .....	2-11
6. Printer Mask .....	2-12

2.2.2 Ver-01.02	2-13
1. Receiver Mode	2-13
2. Local Channel	2-14
3. Auto Print	2-14
4. Rcv Station & Msg	2-15
5. User Select Station & Msg	2-15
2.3 Setting of System menu	2-16
1. Warn Msg Alm	2-16
2. Signal Monitor	2-17
3. Key Beep	2-17
4. Time Offset	2-18
5. Units	2-18
6. Printer	2-19
2.4 Setting of Display menu	2-20
1. Scrolling	2-20
2. Font Size	2-20
3. Time Display	2-20
4. Date Display	2-21
5. User Display	2-21
6. Speed Display	2-22
7. Contrast	2-22
8. User Select Station & Msg (Ver-02.01)	2-22
2.5 Setting of Service menu	2-23
1. INS Input Speed	2-23
2. INS Output Speed	2-23
3. Print Header	2-23
4. Edit Station List	2-24
5. Default Setting	2-24
6. Test	2-24
7. Rcv Monitor	2-24
2.6 Setting of Initialize-1 menu	2-25
1. Delete All Msgs	2-25
2. All Clear	2-25
3. Demo Mode	2-25
4. System Test Results	2-25
5. View Nav Data	2-25
6. ZCZC Check	2-26
7. 00 Msg Priority	2-26
8. Print Order	2-26
9. Available Rcv Station List	2-27
10. Adjust Rx Unit	2-27
11. Rx Test	2-27

2.7 Setting of Initialize-2 menu .....	2-28
1. Sumless NMEA .....	2-28
2. ACK Command .....	2-28
3. Serviceman Test .....	2-28
4. Fill Memory .....	2-28
5. Rcv Mon+NMEA Test .....	2-28
6. DX RX Decision .....	2-29
7. CR LF Check .....	2-29
8. Russia Mode .....	2-30
2.8 Setting of printer $\mu$ TP-58E-FU .....	2-31
2.8.1 Default setting of DIP SW .....	2-31
2.8.2 Switch operation .....	2-31

### Chapter 3. Parts Location

3.1 NX-700A .....	3-1
3.2 NX-700B .....	3-5
3.3 Receiver unit: NX-7001 .....	3-8
3.4 Antenna unit: NX-7H .....	3-10

### Chapter 4. Menu Tree

4.1 User Menu Tree .....	4-1
4.1.1 Program Ver-01.02 .....	4-1
4.1.2 Program Ver-02.01 .....	4-2
4.2 Initialize1, 2 Menu Tree .....	4-3
4.2.1 Program Ver-01.02 .....	4-3
4.2.2 Program Ver-02.01 .....	4-3

## Chapter 5. Block Description

5.1 Configuration	5-1
5.1.1 NX-700A	5-1
5.1.2 NX-700B	5-1
5.2 Connection	5-2
5.2.1 Overview of connection	5-2
1. NX-700A	5-2
2. NX-700B	5-2
3. Overview of boards	5-3
5.2.2 Input/output specifications	5-3
1. Receiver unit	5-3
2. Display unit: NX-700A/B	5-4
3. Printer: $\mu$ TP-58E-FU	5-5
5.3 Block Description	5-6
5.3.1 Receiver unit	5-6
1. RCV (08P3227)	5-6
5.3.2 Display unit	5-8
1. CPU board (08P3225)	5-8
2. PWR (08P3226)	5-12
3. Printer ( $\mu$ TP-58E-FU)	5-13
5.3.3 Antenna unit (NX-7H)	5-14

## Chapter 6. Program Update

6.1 Overview	6-1
6.1.1 Program file	6-1
6.1.2 Notices	6-1
6.1.3 Preparation	6-2
1. Connection	6-2
2. Procedure for rewriting COM port of batch file	6-3
6.2 Procedure for updating	6-4
6.2.1 Procedure	6-4
6.2.2 Check of program number	6-6



## Chapter 7. Maintenance

Call up the Initialize menu .....	7-1
7.1 Self Test .....	7-1
7.1.1 [MENU] -> Service -> Test .....	7-1
7.1.2 [MENU] -> Initialize 2 -> Serviceman Test .....	7-5
7.1.3 Factory Test .....	7-6
7.2 Rcv Monitor .....	7-10
7.2.1 [MENU] -> Service -> Rcv monitor .....	7-10
7.3 Test in Initialize-1 and Initialize-2 menus .....	7-12
7.3.1 Test in Initialize-1 menu .....	7-12
1. System Test Results .....	7-12
2. Initialize1 -> View Nav Data .....	7-12
3. Adjust Rx Unit .....	7-13
4. Rx Test .....	7-13
7.3.2 Tests in Initialize-2 menu .....	7-14
1. Serviceman Test .....	7-14
2. Fill Memory .....	7-14
3. Rcv Mon + NMEA Test .....	7-14
7.4 Memory Clear .....	7-15
7.5 Popup Message .....	7-17
7.6 Replacement of Battery .....	7-20
7.7 Troubleshooting .....	7-21
1. The power is not turned on. ....	7-21
2. Reception trouble-1) No reception .....	7-22
3. Reception trouble-2) There are many reception errors. ....	7-23
4. NMEA data is not inputted from the GPS. ....	7-24
5. The printer does not operate. ....	7-25

**Chapter 8. Q &A**

Q1. Can the FAX-5 antenna unit be used with NX-700A and B? ..... 8-1

Q2. Can the NX-5 antenna unit be used with NX-700A and B? ..... 8-1

Q3. Give information on the specifications of a connectable printer. .... 8-1

Q4. What part should the Nav data (GPS) be connected to? ..... 8-1

Q5. What is the length of the cable between the Display unit and  
the Receiver unit? ..... 8-1

Q6. When the NX-700A/B is used at an exhibition and presentation,  
is it needed to connect the Antenna unit? ..... 8-1

Q7. Is there any difference according to the input power (+12/24VDC)? ..... 8-1

Q8. The INS connection port is of the RS-485 type. How is the ON/OFF  
setting of the terminating resistor performed? ..... 8-1

Q9. Under what conditions is an alarm outputted? ..... 8-2

Q10. How can the alarm output be checked? ..... 8-2

Q11. Should only pressing any key stop an alarm? ..... 8-2

Q12. Power cannot be turned on. What parts should be checked? ..... 8-2

Q13. Nav data is not displayed. What parts should be checked? ..... 8-2

Q14. The received time does not display in the receiving list. .... 8-3

Q15. What does the “Distance” showed on the user display represent? ..... 8-3

Q16. Messages cannot be received even in receiving time. .... 8-3

Q17. Although the icon showing the “During receiving” on 518 kHz is displayed,  
a message cannot be received. .... 8-3

Q18. Although the received signal intensity seems to be strong enough,  
a message cannot be received. .... 8-3

Q19. A received message cannot be printed. .... 8-3

Q20. The icon  showing “during printing” is displayed  
in the Status field of NX-700B (not incorporating a printer). .... 8-3

Q21. A new station starts operation. Is it needed to change the program or  
circuit to receive messages from this station? ..... 8-4

Q22. How can the program number be checked? ..... 8-4

Q23. A program cannot be updated. .... 8-4

Q24. The icon showing “Battery drain” is displayed. What problems should occur? ... 8-4

Q25. What is the important information of the Operator’s Manual? ..... 8-4

**Specifications** ..... **AP1-1**

**Part List** ..... **D-1**

**Contents of Drawings** ..... **S-0**

This page is intentionally left blank.



4. Can a message be received? If not, check the following points:
- 1) Is the power of +9 VDC applied to the antenna terminal of NX-7001?
  - 2) Execute “[MENU] -> Service -> Test”. If the result of the Rx Test is OK, the problem is not with the Receiver unit.
  - 3) If possible, replace the Antenna unit to FAX-5 type for checking. When a message can be received by this, the problem is with the Antenna unit.

Apply the power +9 VDC to antenna unit.

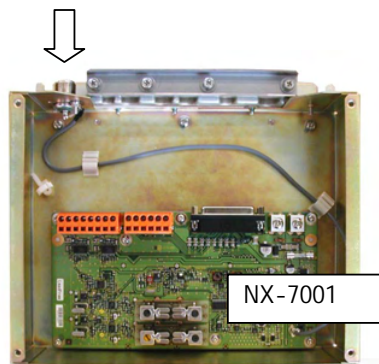

[MENU] -> Display -> User Display  
-> Select Nav Data

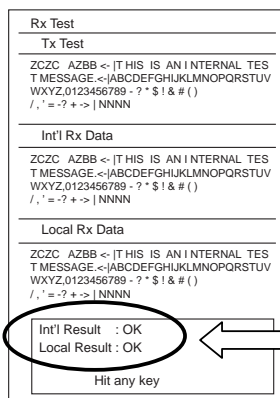

Rx Test OK?

5. Check the program version. See page 6-6 for details.  
Execute “[MENU] -> Initialize2 -> Serviceman Test”.

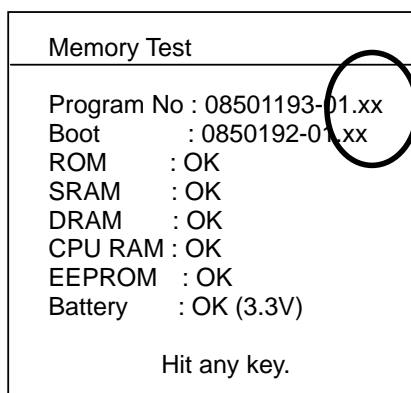

Detailed program version

**Note:**  
The program number displayed by the setting of “[MENU] -> Service -> Test” is the version in conformity with the requirements for the type approval.

6. Memory can be cleared by the following method. See page 7-15 for details.
- To clear user setting : [MENU] -> Service -> Default Setting
  - To clear all : [MENU] -> Initialize1 -> All Clear
  - To clear received messages : [MENU] -> Initialize1 -> Delete All Msg

## 1.1 Overview

### 1.1.1 Configuration

This equipment is a dedicated NAVTEX receiver designed in conformity with the revised NAVTEX Manual that can simultaneously receive two frequencies. Since July 2005, a vessel equipped with a NAVTEX receiver should be equipped with devices meeting these requirements.

The available language is English and not multilingual. While broadcasting on the International Navtex frequency of 518 kHz is available in English, broadcasting in a local language may be available a local frequency of 490 kHz or 4209.5 kHz in some countries by converting into the language of the country using the NAVTEX code (4B-3Y).

The general requirements set out in the Resolution MSC.148 (77) includes the following requirements:

*The equipment should comprise radio receivers, a signal processor and:*

- 1. an integrated printing device; or*
- 2. a dedicated display device, printer output port and a non-volatile message memory;*
- 3 a connection to the INS (Integrated Navigation System) and a non-volatile messages memory.*

#### **Reference:**

1. Simultaneous two frequency (dual channel) reception means that the equipment receives the international NAVTEX frequency of 518 kHz and a local frequency of 490 kHz or 4209.5 kHz at the same time and decodes messages on two frequencies.
2. The connection to the INS means that the equipment performs NAVTEX alarm reset (\$ACK), transmission of received NAVTEX information to the INS (\$NRX), and setting of station selection and message selection (\$NMK) from the INS to the NAVTEX, through the use of sentences in IEC61162-1/2 format.

The international standards complied with are as follows;

- |                                  |                          |
|----------------------------------|--------------------------|
| - MSC.148 (77)                   | - IMO A.694 (17)         |
| - IEC 61097-6 Ed.2 CDV (2005-02) | - IEC 60945 Ed. 3/4      |
| - IEC 61162-1/2                  | - EN 300 065V 1.1.3      |
| - EN 301 011V 1.1.1 (1998-09)    | - ITU-R M 540-2, M 625-3 |

The equipment configuration comprises an Antenna unit of the magnetic-field type NX-7H, a Receiver unit NX-7001, and either of two types of Display units NX-700A which incorporates an LCD and a printer or NX-700B as a discrete device.

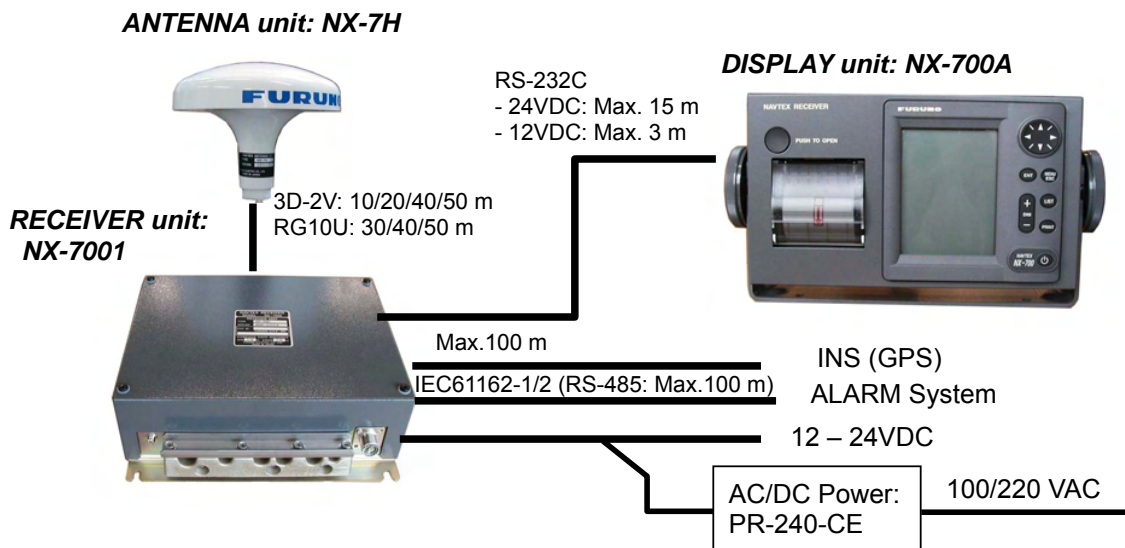

Fig. 1.1.1 Configuration of NX-700A

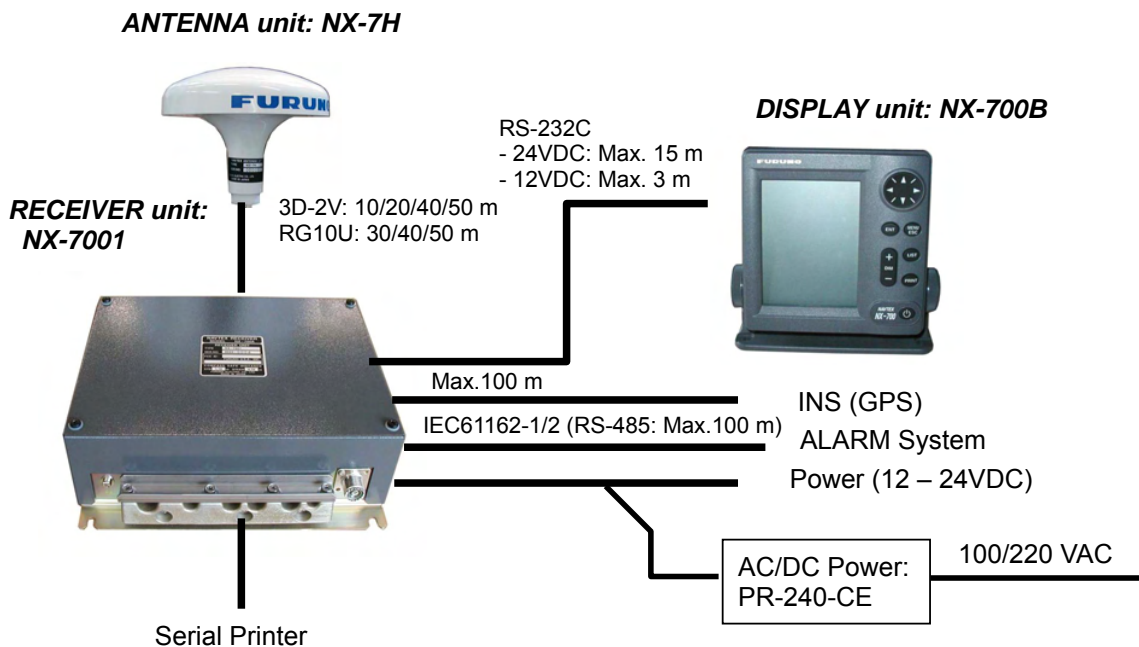

Fig. 1.1.2 Configuration of NX-700B



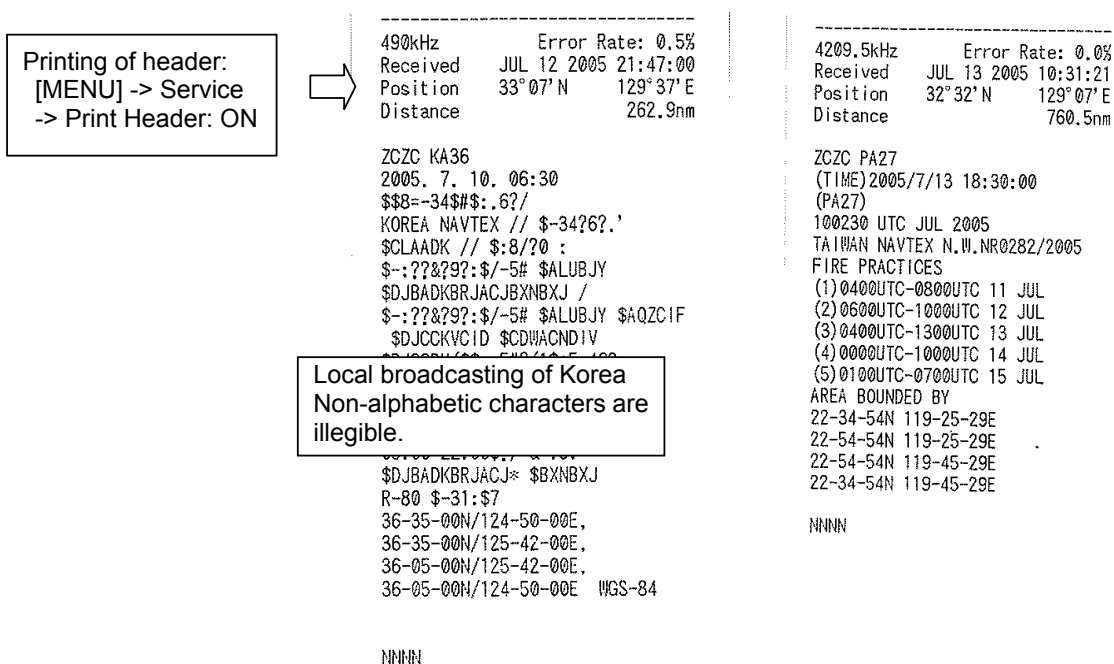

Fig. 1.1.3 Example of printing

## 1.1.2 Installation

1. Install the Display unit NX-700A or NX-700B at a place where the ship is normally navigated.
2. Input the ZDA sentence. Without the entry of the ZDA sentence, the time stamp on the header of printing and the reception time to be displayed in the reception list are shown blank.
3. Input NAV data.  
Without the input of the position data, the Auto mode: Automatic station selecting function does not work and broadcasting from all stations is received. In this case, NAVTEX stations are to be manually set.  
The following sentences of IEC61162-1/2 can be accepted;

```

- Time and date      : ZDA
- Position           : GNS > GGA > RMC > GLL
- SOG                : VTG > VBW > RMC
- STW                : VHW > VBW
- COG                : VTG > RMC

```

## 1.2 Operation Guide

### 1.2.1 NAVTEX system

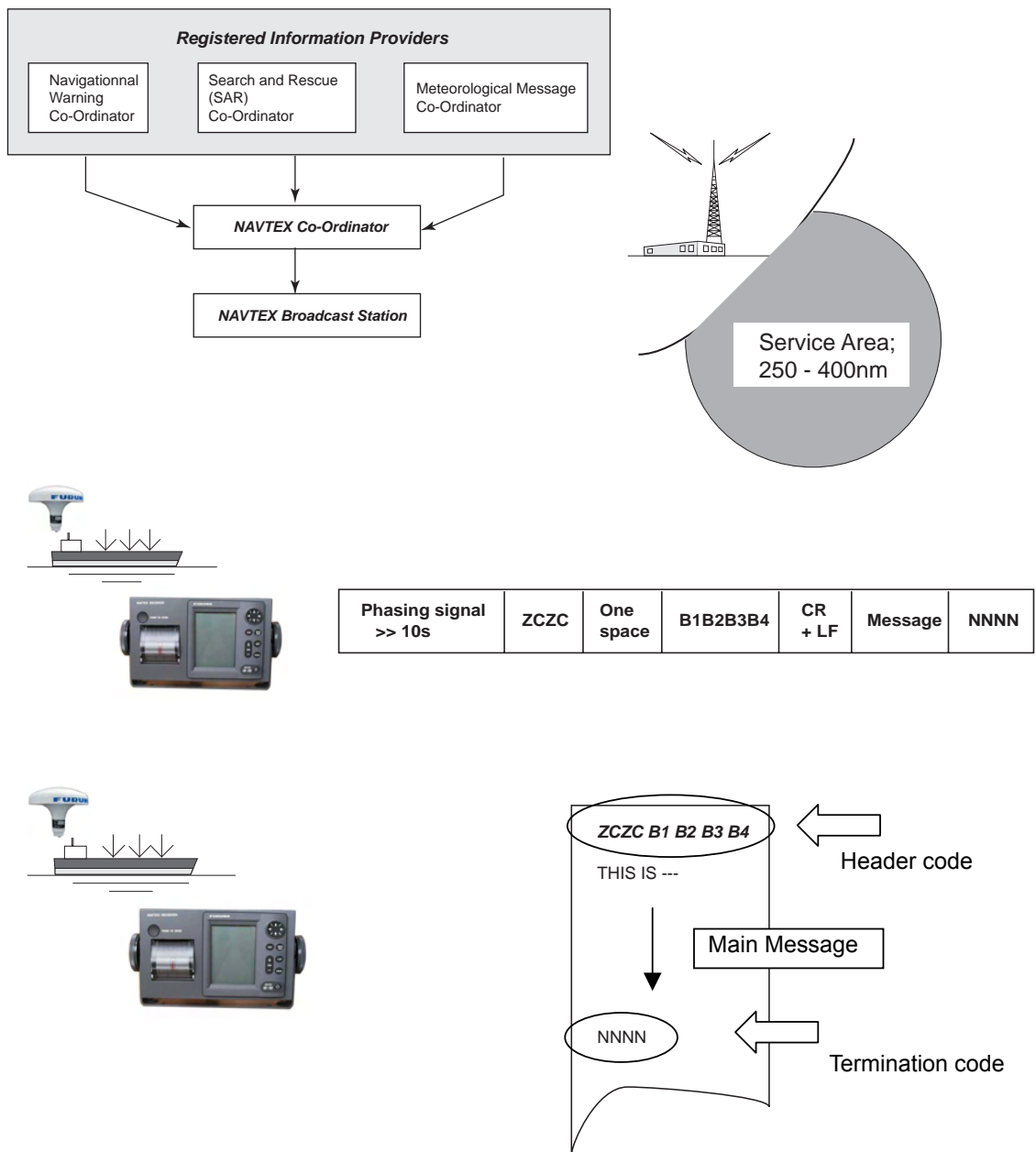

Fig. 1.2.1 NAVTEX system

In the NAVTEX system, stations allocation on the NAVAREA are divided into four groups (A-F, G-L, M-R and S-X). Each group has a capacity for broadcasting six times a day (every four hours) and at intervals of 10 minutes.

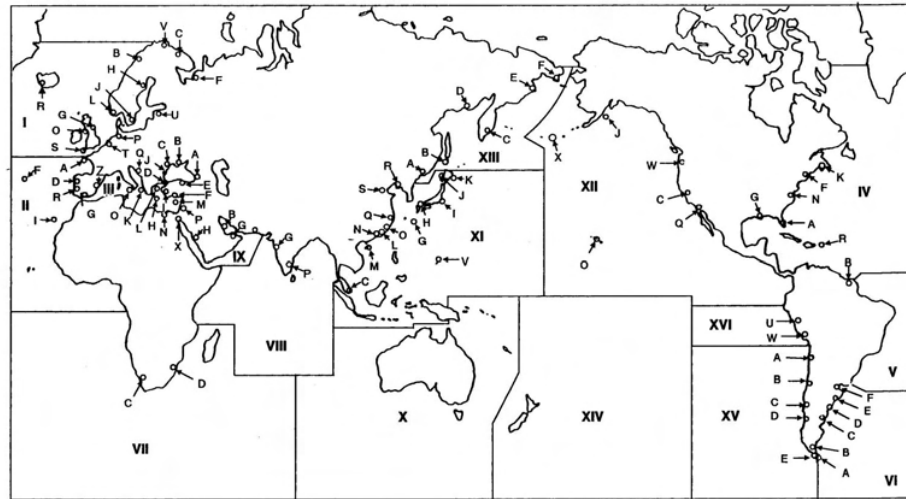

Fig. 1.2.2 Allocation of NAVTEX stations

#### **Header code**

ZCZC: Start code    B1: Station ID    B2: Message ID  
 B3, B4: Message No. (00: Urgency Message, 01 to 99: Normal Message)

#### **Message ID**

**A=Navigational warnings**  
**B=Meteorological warnings**  
 C=Ice reports  
**D=Search and Rescue information, and pirate attack warnings**  
 E= Meteorological forecasts  
 F=Pilot service messages  
 G=AIS  
 H=LORAN messages  
 I=Spare  
 J=SATNAV messages  
 K=Other electronic navaid messages  
**L=Navigational warnings – Additional to letter A**  
 V to Y=Special service allocation by the NAVTEX Co-ordinating Panel  
 Z=No messages on hand

#### **Note:**

A user cannot reject receiving messages A, B, D and L by editing: User select Msg.

### 1.2.2 Auto mode: Automatic station selecting function

When a position data is entered, the Auto mode can be used. The range of the selection is specified in “Area: nm” in the NAVTEX Station List of the Operator’s Manual.

**Note:**

The information on the service area of each station is extracted from the Cost station List issued by the ITU. For example, the service area of Yokohama is 400 nm. The area of 800 nm with this station at the center is the area to allow Auto mode.

In Serapeum in Egypt, the frequency of 4209.5 kHz is used but “Area: nm” is not specified because it is in the HF band.

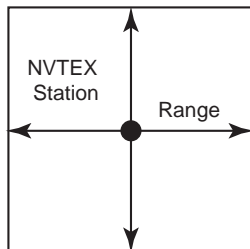

Fig. 1.2.3 Auto mode area

1. A user can switch between Auto mode: Automatic station selecting and Manual mode: Manual station selecting modes.
2. The Auto mode is switched between 518 kHz/490 kHz and 518 kHz/4209.5 kHz with the two frequencies in pairs. Auto mode is not available for each frequency separately.
3. The positions, IDs, service area ranges of NAVTEX stations are stored in the nonvolatile memory.
4. The entry of position information is required to enable the Auto mode.

When there is no input of position information

- 1) Messages from all NAVTEX stations are received (All stations selected)

When there is an input of position information

- 1) When the own ship is located within the service area of a NAVTEX station, the ship receives messages from the NAVTEX station. Otherwise, messages from the NAVTEX station are not received.
- 2) When the own ship is located in an area where service areas of multiple NAVTEX stations are overlapped, broadcasting from NAVTEX stations of these service areas is received.
- 3) When the own ship is not in any of service areas, messages from all NAVTEX stations are received (All stations selected).
- 4) When the own ship is located in the service area of a NAVTEX station that broadcasts only at 518 kHz, all NAVTEX stations are selected on 490 kHz.
- 5) When the own ship is located in the service area of a NAVTEX station that broadcasts only at 490 kHz, all NAVTEX stations are selected on 518 kHz.
- 6) In Auto mode, all NAVTEX stations are selected by receiving at 4209.5 kHz. Because it is the HF band that the service area is not specified by the propagation of ionosphere.

### 1.2.3 Saving of NAVTEX message

Received messages are saved in the memory (SRAM) which is backed up by a battery.

1. The number of messages that can be stored is up to 200 messages for the international frequency and the local frequency, respectively (The average number of characters of one message is 500). Consequently, the number of characters to be stored is  $200 \times 500 \times 2 = 200,000$ .
2. The number of characters in one message is up to 8,000 characters (The maximum number of characters is not defined by the IEC Standard.)
3. A message is deleted from the memory under the following conditions, except those protected on the [LIST] menu.
  - 66 hours have passed after it was received.
  - Older message than the 200th message counting from the newest message
4. A message having the character error rate exceeding 33 % is not saved.
5. When a message having the character error rate between 4 % and 33 % (inclusive) has been saved, and when a better message of the same ID with a less character error rate than the older one is received, the older message with the worse character error rate is deleted.

When a message with a character error rate of 4 % or less has been saved, a message of the same ID is not received.

A message having the serial number "00" is always received regardless of the character error rate.
6. Each message can be protected from being deleted by the setting on the [LIST] menu. Protection can be provided for up to 50 messages for the international and the local frequency, respectively, or up to 25 % of the message memory.

## 1.2.4 Operation Guide

### 1. Status display

Icon	Status	Meaning
	Blinking	Shows that there is an unread message on the international frequency (518 kHz).
	Blinking	Shows that there is an unread message on the local frequency (L1: 490 kHz, L2: 4209.5 kHz).
	Blinking	
	Blinking	Shows that a message is being received. I: International frequency (518 kHz), L1: Local frequency (490 kHz) L2: Local frequency (4209.5 kHz) In the Russia mode, an icon corresponding to the selected frequency lighting.
	Blinking	
	Blinking	
	Lighting	Shows that the voltage of the battery for backup of memory (SRAM) goes down below +2.5 VDC. The display also shows a popup message as "Battery error". When this error message is displayed, replace the lithium battery of the CPU board. Voltage adequate for SRAM (received message) backup is +1.8 VDC or more. <b>Related setting:</b> [MENU] -> Service -> Test: Battery
	Lighting	Detects "PE" signals outputted from the printer. Printer error: Displayed when paper runs out or printer door open is detected. The display also shows a popup message as "Printer error".
	Lighting	Shows that printing is under way. <b>Related setting:</b> [PRINT] [MENU] -> NAVTEX -> Printer Mask (Ver.02.01) [MENU] -> System -> Printer
	Lighting	Shows that the status is in the DEMO mode. To enter this mode, select "ON" in [MENU] -> Initialize1 -> Demo.

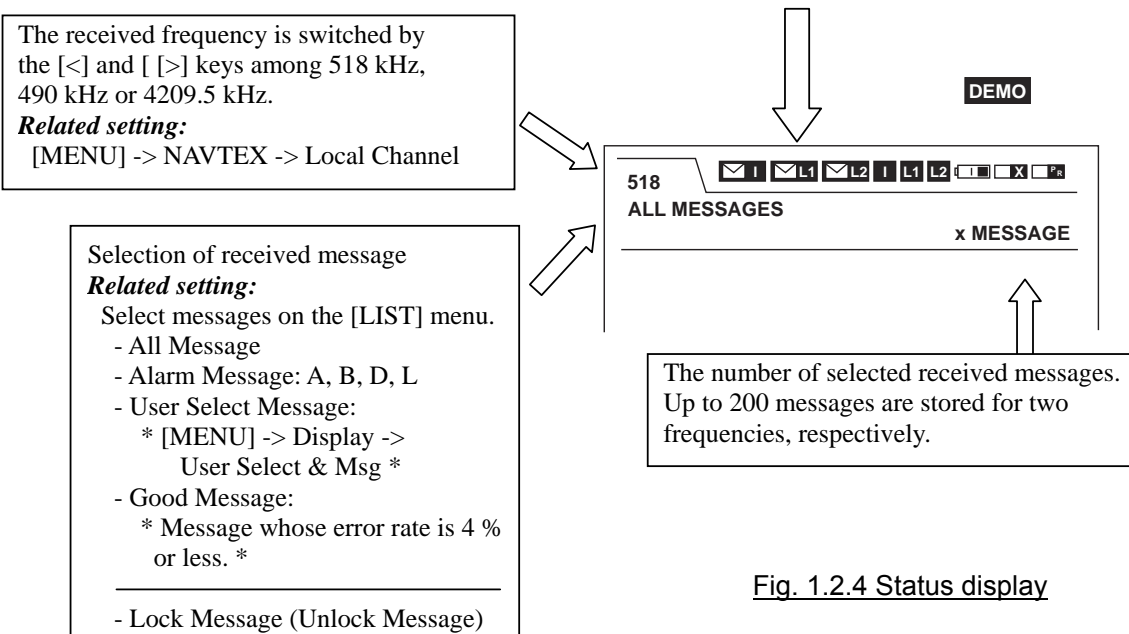
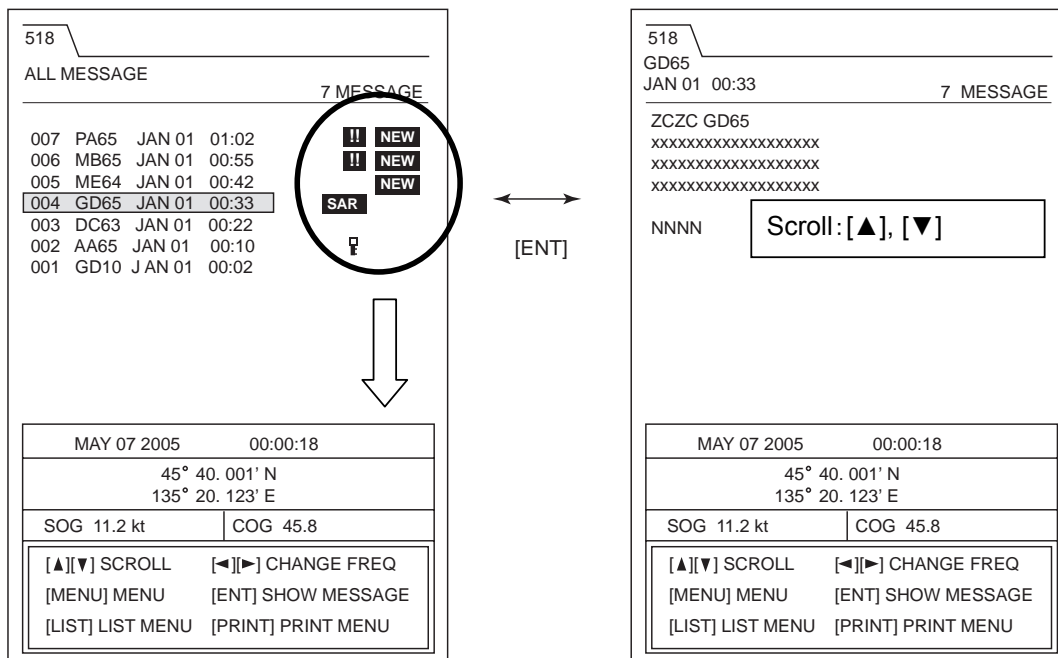

Fig. 1.2.4 Status display



Icon	Status	Meaning
<b>NEW</b>	Lighting	Shows that there is an unread message. When the received message is opened, the icon disappears. Also disappears when 24 hours have passed.
<b>SAR</b>	Lighting	Shows that the message is an SAR message (D). When an SAR message is received: - Alarm beeps are given. - The information of the SAR message is displayed. - An alarm output signal is turned on. To stop the alarm, press any key other than the power key. The message list is automatically changed to "All Message".
<b>!!</b>	Lighting	Shows that the message is a WARNING message (A/B/L). When the message is received, a popup window showing "Received new Warning Message" appears. <b>Related setting:</b> When "ON" is selected in [MENU] -> System -> Warn Msg Alm: - Alarm beeps are generated. - An alarm output signal is turned on. To stop the alarm, press any key other than the power key.
<b>🔒</b>	Lighting	Shows that the message is a protected message. A protected message is not deleted even after 66 hours have passed after its reception and even when the memory becomes filled up. Note that up to 50 messages can be protected within the limit of 25 % of the memory capacity. <b>Related setting:</b> [LIST] -> Lock Message, Unlock Message

Fig. 1.2.5 Message status

## 2. User display

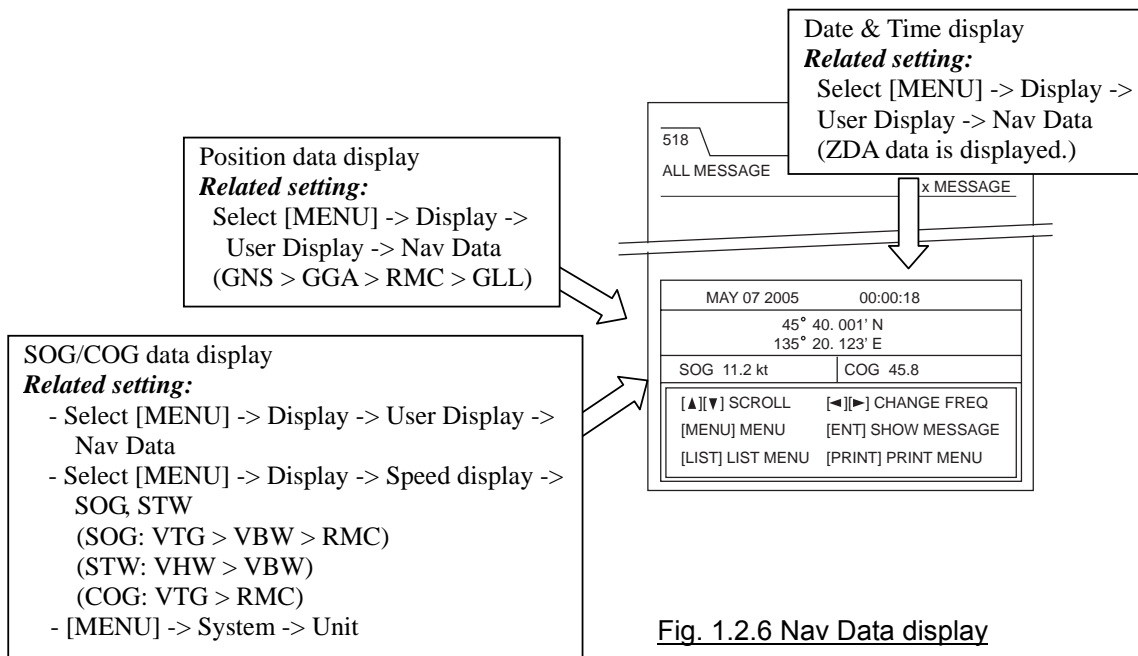
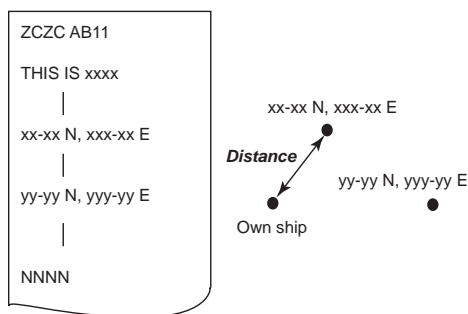
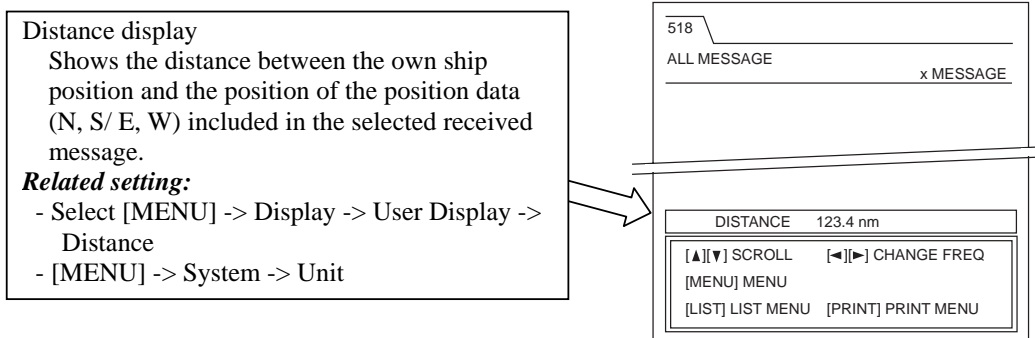

Fig. 1.2.6 Nav Data display



This display is intended as information so that a user can make a judgment as to whether the received message is relevant to the own ship, on the basis of the own ship position and the position information included in the received message.

For instance, if the position data of X and Y is included in the received message, the distance to X is calculated since the position X is nearer to the own ship position than the position Y.

Fig. 1.2.7 Distance display



# Chapter 2. System Setting

## Overview

### 1. To call up the Initialize menu

The menu includes the Initialize1 and Initialize2 menus as option menus. These menus include special settings and items related to maintenance. To call up these menus, hold down both the [+] and [-] keys of the DIM for over 5 seconds on a screen on which the popup display is not shown and the received message list or received messages are shown.

The Initialize1 and Initialize2 menus are added in the menu list as shown below.

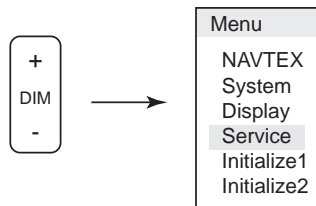

### 2. Program

The program which complies with the “IEC Standard” is Ver-01.02 and the program which complies with the “Russia type approval” is Ver-02.01. The table below shows the differences of these programs.

Table 2.1 Program version

Different points	Program Version	
	Ver-02.01	Ver-01.02
NAVTEX menu	Mask Mode Auto Rcv Mask/ Local Channel/Rcv Mask/ INS Output Mask/Printer Mask	Receiver Mode/ Local Channel/Auto Print/ Rcv Station & Msg/ User Select Station & Msg
Display menu	“User Select Station & Msg” is present.	“User Select Station & Msg” is not present.
Initialize2 menu	Russia Mode is present.	Russia Mode is not present.
Initialize2 -> ACK Default of Command	Receive	Ignore
Initialize1 -> 00 MSG Default of Priority	B1 > 00 > B2	B1 > 00 > B2, but it is set to 00 > B1 > B2 as the default.
Distinction and stop of warning alarm beeps	See page 2-17.	
Whether or not to output \$ALR to the serial output when a warning alarm is generated.	Output	Not output

### 3. Setup Guide

Configure the setting according to the needs of each user.

This NX-700A/B receives NAVTEX messages in the default setting as it is. Basically, the NAVTEX, System, Display and Service menus are to be set by users. Do not attempt to change the settings of the Initialize1 and Initialize2 menus needlessly.

If they have to be changed, do it after understanding the functions of them.

Table 2.2 User Setup Guide

Menu	Item	Setting	Remarks	Page
NAVTEX <u>Ver-02.01</u>	Mask Mode	INS	Select "INS" to set the Rcv Mask by sentences from the INS.	2-8
		<b>Manul</b>		
	Auto Rcv Mask	Off	Normally ON	2-9
		<b>On</b>	Setting to enable the Auto mode	
	Local Channel	<b>490kHz</b>	Selection of receiving frequency	2-10
		4209.5kHz		
	Rcv Mask	Station : A-Z Message: A-Z	Setting of stations and message types. The default setting is "Select All".	2-10
INS Output Mask	Station : A-Z Message: A-Z	The default setting is "Select All". Selection of stations and messages to be outputted to the INS.	2-11	
Printer Mask	Station : A-Z Message: A-Z	Setting of printer output	2-12	
NAVTEX <u>Ver-01.02</u>	Receiver Mode	INS	Normally "Auto" When "Auto" is selected, the Auto mode is enabled.	2-13
		<b>Auto</b>		
		Manul		
	Local Channel	<b>490kHz</b>	Selection of receiving frequency	2-14
		4209.5kHz		
	Auto Print	Off	Setting of printer output when a message is received.	2-14
<b>All</b>				
	User Select			
Rcv Station & Msg	Station : A-Z Message: A-Z	Setting of stations and message types. The default setting is "Select All".	2-15	
User Select Station & Msg	Station : A-Z Message: A-Z	Setting of sorting items of station and message type in "User Select Message" on the [LIST] menu.	2-15	
System <i>Cont'd</i>	Warn Msg Alm	<b>Off</b>	Setting of ON/OFF of alarm beep when a message A, B or L is received.	2-16
		On		
	Signal Monitor	<b>Off</b>	Selection of the frequency to be monitored.	2-17
		Int'l		
		Local		
Key Beep	Off	ON/OFF of Key beep setting	2-17	
	<b>On</b>			
Time Offset	<b>+ 00:00</b>	Time difference of time display setting	2-18	

*Cont'd*

Menu	Item	Setting	Remarks	Page
System	Units	<b>nm, kt</b>	Unit display of Nav data Setting	2-18
		km, km/h		
		mi, mi/h		
	Printer	None	Type of connected printer setting	2-19
		<b>NX-700A</b>		
Upright				
	Inverted			
Display	Scrolling	<b>Slow</b>	Setting of scrolling	2-20
		Fast		
		Skip To \$\$		
	Font Size	Small	Setting of character size of received message <b>Note:</b> The font size “Small” and “Large” are not order to the IEC Standard.	2-20
		<b>Medium</b>		
		Large		
	Time Display	<b>24 hour</b>	Setting of time display	2-20
		12 hour		
	Date Display	<b>MMM DD YYYY</b>	Setting of date display	2-21
		DD        MMM YYYY		
		YYYY    MMM DD		
	User Display	<b>Off</b>	ON/OFF of Nav Data display or Distance display setting <b>Note:</b> “Off” is order to the IEC Standard.	2-21
		Nav Data		
		Distance		
	Speed Display	<b>SOG</b>	Speed display of Nav data selecting	2-22
STW				
Contrast	0 – 9 <b>(5)</b>	Setting of contrast	2-22	
User Select Station & Msg <b>Ver-02.01</b>	Station: A – Z Message:A - Z	Sorting item of message type and station setting in “User Select Message” on the [LIST] menu	2-22	
Service	INS Input Speed	<b>4800bps</b>	Setting of communication speed with INS (GPS)	2-23
		9600bps		
		19200bps		
		38400bps		
	INS Output Speed	<b>4800bps</b>	Setting of communication speed with INS	2-23
		9600bps		
		19200bps		
		38400bps		
	Printer Header	Off	ON/OFF of header setting in printer output	2-23
		<b>On</b>		
	Edit Station List	Nav Area 1 – 16, EXT	Setting for addition, deletion and edition of NAVTEX station	2-24
	Default Setting	Restore default settings ?	Reset the user menu to the default	2-24
	Test	Start test ?	Self-test	2-24
Rev Monitor		Display a messages being received in real time	2-24	

Table 2.3 Initialize Setup Guide

Menu	Item	Setting	Remarks	Page
Initialize 1	Delete All Msg		Deletion of received message	2-25 7-15
	All Clear		All settings are reset to default settings and received messages are deleted.	2-25 7-15
	Demo Mode	<i>Off</i> On	ON/OFF of Demo Mode setting	2-25
	System Test Results		Display of factory self test results	2-25 7-12
	View Nav Data		Display of input Nav data	2-25 7-12
	ZCZC Check	<i>Off</i> On	Handling of "ZCZC" setting	2-26
	00 Msg Priority	B1>00>B2 <i>00&gt;B1&gt;B2</i>	Handling of "00" message setting	2-26
	Print Order	<i>Old -&gt; New</i> New -> Old	Printing order of messages setting in the received message list (printing order starting from oldest message/ order starting from newest message)	2-26
	Available Rcv Station List		Display currently receivable station and message type	2-27
	Adjust Rx Unit		NX-7001 adjust mode	2-27 7-13
	Rx Test		Receiving self test	2-29 7-13
Initialize 2	Sumless NMEA	<i>Ignore</i> Receive	Handling of NMEA sentence with or without checksum	2-27
	ACK Command	<i>Ignore</i> Receive	Setting whether to enable or disable the \$ACK sentence from the INS	2-28
	Serviceman Test		Self test for serviceman	2-28 7-5
	Fill Memory		Setting for type approval to fill the message storage area to the 100 % use status.	2-28 7-14
	Rev Mon+NMEA Test		Display a message being received in real-time Loop Back test of NMEA data	2-28 7-14
	DX RX Decision	<i>Soft</i> Hard	Setting for character recognition	2-29
	CRLF Check	<i>Off</i> On	Setting whether to enable or disable <CR> and <LF> check	2-29
	Russia Mode <i>Ver-02.01</i>	<i>Off</i> On	Selection of Russia or IEC standard	2-30

## 2.1 Nav data

Input position data such as GGA to enable the Auto mode.

Input ZDA sentences of the Time/Date data to display the time of a received message.

Table 2.1.1 Nav Data

Data	Sentence
Time/Date	ZDA
Position	GNS > GGA > RMC > GLL
SOG	VTG > VBW > RMC
STW	VHW > VBW
COG	VTG > RMC

Case-1)

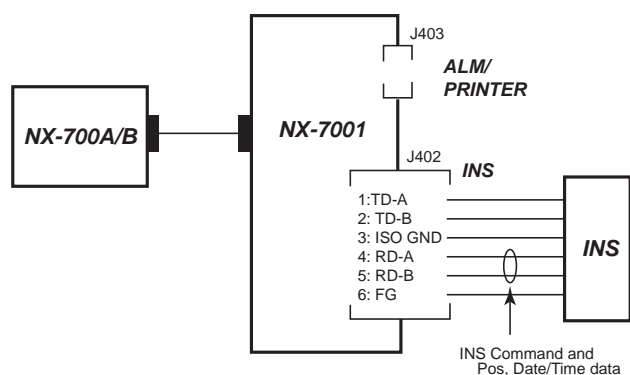

Case-2)

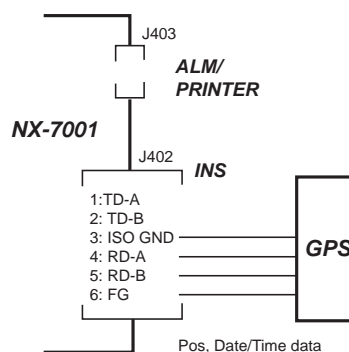

To connect to the INS (Integrated Navigation System), include the position data and Time/Date data in the data from the INS.

Fig. 2.1.1 Connection of Nav Data

### 2.1.1 Setup of Nav data input

- [MENU] -> Service -> INS Input Speed (4800/9600/19200/34800)
- [MENU] -> Initialize 2 -> Sumless NMEA (Receive/Ignore)

#### *INS Input Speed:*

Select the bit rate for serial data input of the Nav data.

#### *Sumless NMEA:*

Select whether or not to load a sentence with or without checksum. Basically, sentences are without checksum in case of NMEA Ver.-1.5 while with checksum in case of Ver.-2.0 and IEC61162.

IEC61162 sentences are required for type approval. Do not connect the GPS outputting sentences without checksum.

#### **Note:**

With no input of the ZDA sentence, the received time is not recorded. With no input of the position data such as GNS and GGA sentences, Auto mode is not enabled and broadcasting of all stations are received(selected).

To enable the Auto mode,

- Program Ver-02.01: Select "ON" in [MENU] -> NAVTEX -> Auto Rcv Mask
- Program Ver-01.02: Select "Auto" in [MENU] -> NAVTEX -> Receiver Mode

#### **Setup:**

1. Select [MENU] -> Service -> INS Input Speed.
2. Set the speed to 4800 in case the NAVTEX data is in IEC61162-1 format. In case the Nav data is inputted from the INS, set the speed according to the specifications of the INS.
3. Select [MENU] -> Initialize 2 -> Sumless NMEA.
  - "Receive" : NMEA Ver.1.5 (no checksum filed in sentence)
  - "Ignore" : NMEA Ver.2.0 or later, IEC61162 (checksum added in sentence)

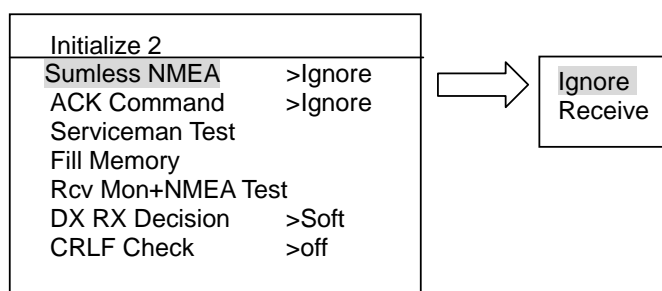

**Nav data Checking:**

Select "Nav Data" in the setting of [MENU] -> Display -> User Display. Check that the position data and Date/Time data are displayed on the screen.

To check whether Nav data is inputted, select [MENU] -> Initialize1 -> View Nav Data.

See page 7-12 for details.

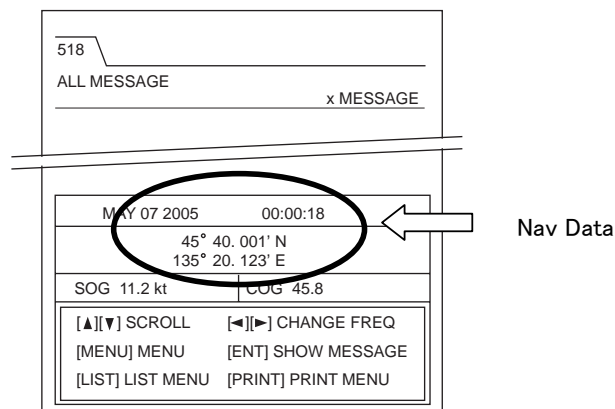

Nav Data Select Screen opened in [MENU] -> Display -> User Display

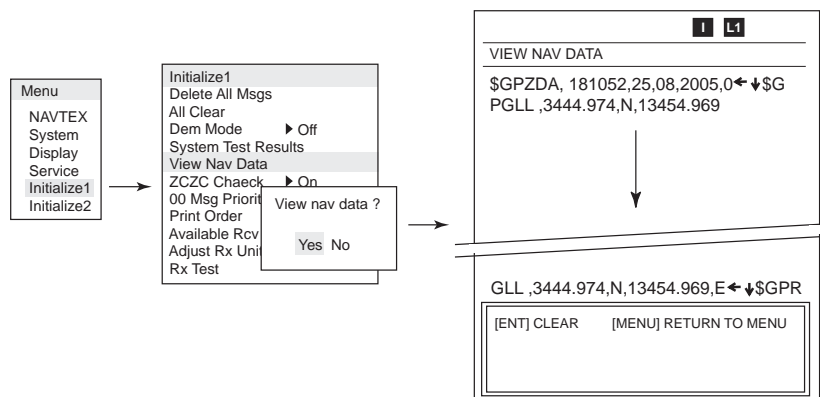

[MENU] -> Initialize 1 -> View Nav Data Screen

## 2.2 Setting of NAVTEX menu

### 2.2.1 Program Ver-02.01

#### 1. Mask Mode

(INS/Manual)

Select whether to set: Mask of “Rcv Mask” on the NAVTEX menu manually or by the command from the INS. To perform the setup manually, select “Manual”. In this case, the Mask set command from the INS is disabled but the Nav data such as the position data and Date/Time data are enabled. To enable the setup by the Mask set command, select “INS”.

When “INS” is selected, the following items disappear and cannot be selected.

- ON/OFF of Auto mode:  
[MENU] -> NAVTEX -> Auto Rcv Mask
- Setting of local frequency:  
[MENU] -> NAVTEX -> Local Channel

Items that can be set from the INS are as follows. These items can be set through IEC sentences from the INS.

- Setting of local frequency (\$NMK)  
[MENU] -> NAVTEX -> Local Channel
- Selection of receiving station and received message (\$NMK)  
[MENU] -> NAVTEX -> Rcv Mask

#### **Related setting:**

- [MENU] -> NAVTEX -> Rcv Mask
- [MENU] -> Service -> INS Input Speed
- [MENU] -> Service -> INS Output Speed



## 2. Auto Rcv Mask

(On/Off)

This is the setting of On/Off of the Auto mode. See page 1-6 for the details of this function.

This setting is enabled when "Manual" is selected in [MENU] -> NAVTEX -> Mask Mode. If "INS" is selected for the "Mask Mode", this setting item is not displayed on the menu.

### When set to "On"

Receiving stations are selected by calculation based on the own ship position data and the service area of the station. The selection of "Station" is disabled in the setting of [MENU] -> NAVTEX -> Rcv Mask, and the selected stations alone are displayed, although "Message" can be selected.

In the Auto mode, stations are selected based on the data of [MENU] -> Service -> Edit Station List. For this reason, these data needs to be changed when the position and service area of the station are changed.

### When set to " Off "

Receiving stations are selected manually.

To select stations, select "Station" and "Message" in the setting of [MENU] -> NAVTEX -> Rcv Mask.

### Related setting:

[MENU] -> NAVTEX -> Mask Mode

[MENU] -> NAVTEX -> Rcv Mask

Rcv Mask	[Manual]
[518]	
Station	▶ ABCDEFGHIJKLMNOPQRSTUVWXYZ
Message	▶ ABCDEFGHIJKLMNOPQRSTUVWXYZ
[490] (or [4209.5])	
Station	▶ ABCDEFGHIJKLMNOPQRSTUVWXYZ
Message	▶ ABCDEFGHIJKLMNOPQRSTUVWXYZ
[▲] [▼] MOVE	
[ENT] EDIT [MENU] RETURN TO MENU	

- Mask Mode: Manual  
→ Manual
- Mask Mode: INS  
→ Auto

- 1) Station  
Mask Mode: INS  
→ Stations selected from the INS alone are displayed.  
Auto Rcv Mask: On  
→ Receivable stations alone are displayed.
- 2) Message  
Mask Mode: INS  
→ Messages specified from the INS alone are displayed.

### 3. Local Channel

**(490kHz/4209.5kHz)**

This is the setting which local frequency, 490 kHz or 4209.5 kHz, should be received. When “INS” is selected in [MENU] -> NAVTEX -> Mask Mode, this setting item is not displayed.

When “4209.5 kHz” is selected, the Auto mode is not enabled on this frequency even if “On” is selected in [MENU] -> NAVTEX -> Rcv Mask. It is because the service area is not consistent due to the feature of HF radio wave propagation.

#### **Related menu operation:**

- 1) Switch between “Local” and “518 kHz” by the [<] and [>] keys on the received message screen.
- 2) [MENU] -> Display -> User Select Station & Msg (Ver-02.01)
- 3) [MENU] -> Service -> Edit Station List
- 4) [MENU] -> Service -> Test
- 5) [MENU] -> Service -> Rcv Monitor
- 6) [MENU] -> Initialize1 -> Demo Mode
- 7) [MENU] -> Initialize1 -> Rx Test
- 8) [MENU] -> Initialize1 -> Available Rcv Station
- 9) [MENU] -> Initialize2 -> Serviceman Test
- 10) [MENU] -> Initialize2 -> Rcv Mon+NMEA Test

### 4. Rcv Mask

This is the setting of the receiving stations and message types for 518 kHz and local frequency (frequency set in “Local Channel”), respectively.

\*\* When “Mask Mode” is set to “Manual”, “Station” and “Message” can be selected.

#### **Station**

**(Default: Receive All)**

- When “Auto” is selected in [MENU] -> NAVTEX -> Auto Rcv Mask, stations automatically selected are displayed.
- When “INS” is selected in [MENU] -> NAVTEX -> Mask Mode, stations specified through NMK sentences from the INS are displayed.

#### **Message**

**(Default: Receive All)**

- This is the setting whether or not to receive messages for each message type. Alarm messages A, B, D and L cannot be set as “Not Receive”.
- When “INS” is selected in [MENU] -> NAVTEX -> Mask Mode, the message types specified through the NMK sentence from the INS are displayed.

#### **Related setting:**

- [MENU] -> NAVTEX -> Mask Mode
- [MENU] -> NAVTEX -> Auto Rcv Mask

**5. INS Output Mask****(Default: Receive All)**

This is the setting of the stations and message types to be outputted to the INS port.

INS Output Mask
[518] Station ▶ ABCDEFGHIJKLMNOPQRSTUVWXYZ Message ▶ ABCDEFGHIJKLMNOPQRSTUVWXYZ
[490] (or [4209.5]) Station ▶ ABCDEFGHIJKLMNOPQRSTUVWXYZ Message ▶ ABCDEFGHIJKLMNOPQRSTUVWXYZ
[▲] [▼] MOVE [ENT] EDIT [MENU] RETURN TO MENU

When a message is received from a station set in [MENU] -> NAVTEX -> Rcv Mask, the message is outputted from the INS port of NX-7001 to the INS through the NRX sentence.

**Related setting:**

[MENU] -> NAVTEX -> Local Channel

**6. Printer Mask****(Default: All Receive)**

This is the setting of the stations and message types to be outputted to the printer. To print a received message, set this to other than “Off” in [MENU] -> System -> Printer. In case of NX-700A, set it to “NX-700A” and in case of NX-700B, set it according to the connected printer type (Invert or Upright).

Printer Mask
[518] Station ▶ ABCDEFGHIJKLMNOPQRSTUVWXYZ Message ▶ ABCDEFGHIJKLMNOPQRSTUVWXYZ
[490] (or [4209.5]) Station ▶ ABCDEFGHIJKLMNOPQRSTUVWXYZ Message ▶ ABCDEFGHIJKLMNOPQRSTUVWXYZ
[▲] [▼] MOVE [ENT] EDIT [MENU] RETURN TO MENU

**Reference:**

When a received message list is displayed and “Print” is executed by pressing the [PRINT] key, all the messages in the list are printed. When a received message is displayed and “Print” is executed, the displayed messages alone is printed.

**Related setting:**

[MENU] -> NAVTEX -> Local Channel

[MENU] -> System -> Printer

## 2.2.2 Ver-01.02

### 1. Receiver Mode

(INS/Auto/Manual)

This is the setting of operation mode of the NX-700A/B.

#### **INS**

Select “INS” for setting the local frequency, receiving stations and message types by the NTK sentence from the INS.

When set to “INS”,

- The setting item of [MENU] -> NAVTEX -> Local Channel is not displayed.
- “Station” and “Message” cannot be selected in [MENU] -> NAVTEX -> Rcv Station & Msg. “Station” and “Message” displayed on the screen are the those set from the INS.

#### **Auto**

This is the setting of On/Off of the Auto mode. See page 1-6 for details.

When set to “Auto”, “Station” cannot be selected in [MENU] -> NAVTEX -> Rcv Station & Msg although “Message” is selectable. Receivable stations alone are displayed on the screen.

#### **Manual**

Receiving stations are selected manually.

When set to “Manual”, set “Station” and “Message” in [MENU] -> NAVTEX -> Rcv Station & Msg.

Rcv Station & Msg	[Manual]
[518]	
Station	
▶ ABCDEFGHIJKLMNOPQRSTUVWXYZ	
Message	
▶ ABCDEFGHIJKLMNOPQRSTUVWXYZ	
[490] (or [4209.5])	
Station	
▶ ABCDEFGHIJKLMNOPQRSTUVWXYZ	
Message	
▶ ABCDEFGHIJKLMNOPQRSTUVWXYZ	
[▲] [▼] MOVE [ENT] EDIT [MENU] RETURN TO MENU	

## 2. Local Channel

(490kHz/4209.5kHz)

This is the setting which local frequency, 490 kHz of 4209.5 kHz, to be received.

When to “INS” is selected in [MENU] -> NAVTEX -> Receiver Mode, this item is not displayed.

### *Related menu operation:*

- 1) Switch between “Local” and “518 kHz” by [<] and [>] keys on the received message screen.
- 2) [MENU] -> NAVTEX -> User Select Station & Msg
- 3) [MENU] -> Service -> Edit Station List
- 4) [MENU] -> Service -> Test
- 5) [MENU] -> Service -> Rcv Monitor
- 6) [MENU] -> Initialize1 -> Demo Mode
- 7) [MENU] -> Initialize1 -> Rx Test
- 8) [MENU] -> Initialize1 -> Available Rcv Station
- 9) [MENU] -> Initialize2 -> Serviceman Test
- 10) [MENU] -> Initialize2 -> Rcv Mon+NMEA Test

## 3. Auto Print

This is the setting of printing of the received message.

- All: Automatically print all received messages.
- User Select: Automatically print only messages specified in [MENU] -> NAVTEX -> User Select Station & Msg
- Off: Received messages are not printed automatically.

### *Reference:*

When a received message list is displayed and “Print” is executed by pressing the [PRINT] key, all the received messages are printed. When a received message is displayed and “Print” is executed, the displayed message is printed.

### *Related setting:*

[MENU] -> NAVTEX -> User Select Station & Message

#### 4. Rcv Station & Msg (Default: Receive All)

This is the setting of the receiving stations and message types for 518 kHz and local frequency (frequency set in “Local Channel”), respectively.

##### **Station** (Default: Receive All)

- When “Auto” is selected in [MENU] -> NAVTEX -> Receiver Mode, stations selected by the Auto mode are displayed.
- When “INS” is selected in [MENU] -> NAVTEX -> Receiver Mode, stations selected through the NMK sentence from the INS are displayed.

##### **Message** (Default: Receive All)

- This is the setting whether or not to receive messages for each message type. Alarm messages A, B, D, and L cannot be set as “Not Receive”.
- When “INS” is selected in [MENU] -> NAVTEX -> Receiver Mode, the message type specified through the NMK sentence from the INS is displayed.

##### **Related setting:**

[MENU] -> NAVTEX -> Receiver Mode

#### 5. User Select Station & Msg (Default: Receive All)

When stations and message types are specified in this setting, the receiving stations and message types selected here are reflected when [User Selected Messages] is selected on the [LIST] menu and “User Select” is selected in [MENU] -> NAVTEX -> Auto Print.

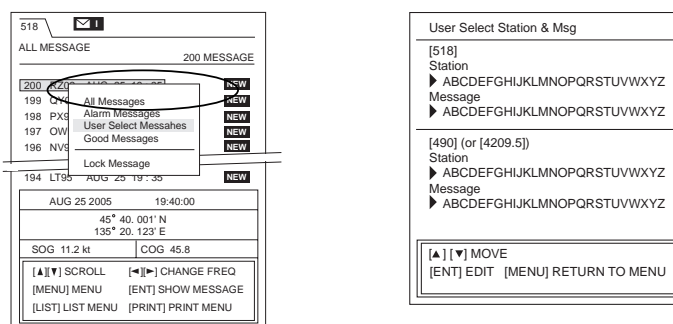

##### **Note:**

- Messages A, B, D and L cannot be set as “Not Display”.
- When [User Select] is selected in [MENU] -> NAVTEX -> Auto Print, only messages selected in [User Select Station & Msg] are printed.

##### **Related setting:**

[MENU] -> NAVTEX -> Auto Print

[LIST] -> User Select Messages

## 2.3 Setting of System menu

The contents of the System menu is same for the programs Ver-01.01 and Ver-02.01.

### 1. Warn Msg Alm

(On/Off)

This is the setting whether or not to output alarm beeps when a warning message A, B or L is received. This setting is linked with ON/OFF of the external alarm signal output. When an SAR message D is received, alarm beeps and an external alarm signal are outputted regardless of this setting.

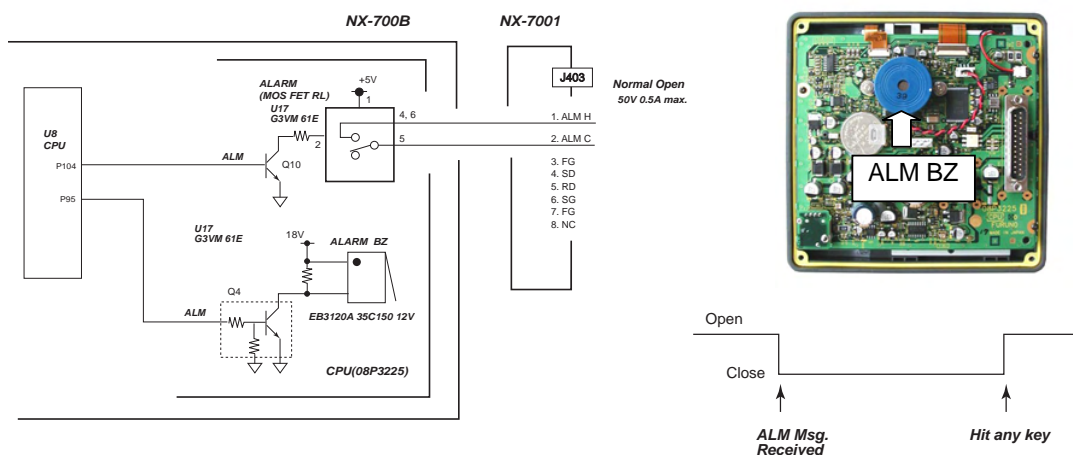

Fig. 2.3.1 Alarm Circuit

### Stop of alarm beep:

To stop alarm beeps and alarm output, press any key other than the power key switch. Alternatively, they can be stopped by the ACK sentence from the INS.

#### Note:

Alarm beeps and alarm output are linked with each other. If alarm beeps are stopped, the alarm output is also turned off.

### Related setting:

Setting for stopping an alarm by the ACK sentence from the INS;

- 1) Select "INS" in [MENU] -> NAVTEX -> Mask Mode (Ver-02.01)
- 2) Select "INS" in [MENU] -> NAVTEX -> Receiver Mode (Ver-01.02)
- 3) Select "Received" in [MENU] -> Initialize2 -> ACK Command



Table 2.3.1 Alarm Operation

Received Msg.	Program Version	ALM beep output	How to stop alarm
A or B or L	01.02	Every second ON/OFF	Stopped by pressing any key
	02.01		1. Stopped by pressing any key 2. Stopped by the sentence from the INS <b>Note:</b> Even when the alarm is outputted by multiple alarm messages, the alarm is stopped by just pressing one key as described above.
D	01.02	Every second ON/OFF	Same as above
	02.01	Every 0.5 s ON/OFF	Same as above
A or B or L+ D	01.02	Every second ON/OFF	1. Stopped by pressing any key 2. Stopped by the sentence from the INS <b>Note:</b> Even when the alarm is outputted by multiple alarm messages, the alarm is stopped by one operation (1 or 2) described above.
	02.01	Every 0.125 s ON/OFF	1. When any key is pressed, the alarm of the message D is stopped. And then when any key is pressed, the alarm of the message A, B, and L is stopped. 2. By the sentence from the INS, alarms of message A, B, L and D are separately stopped.

### 2. Signal Monitor

(On/Off)

This is the setting whether or not to output a receiving monitor beep on the international or local frequency. See page 7-10 for details.

### 3. Key Beep

(On/Off)

This is the setting whether or not to output a beep when a key is pressed.

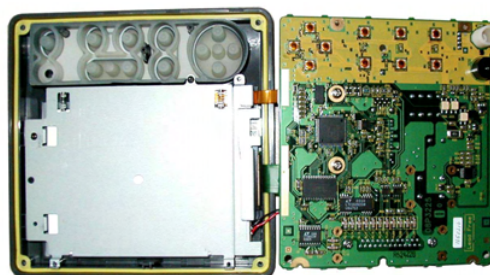

Buzzer  
For Receiving monitor beep,  
Key click beep

**4. Time Offset****(00:00)**

This is the time difference of the time display setting. The items reflecting the time difference are as follows. The setting is not applied to the time in the received message.

- 1) Received time display shown in the received message list display.
- 2) Nav data display field
- 3) Received time of print header

**Related setting:**

[MENU] -> Display -> Time Display

[MENU] -> Display -> User Display

[MENU] -> Service -> Print Header

**5. Units****(nm, kt//km,km/h//mi,mi/h)**

This is the unit of speed and distance display setting on the user display field. This setting is also reflected on the print header (distance).

Note that this is not applied to the speed and time display in the received message.

**Related setting:**

Select [MENU] -> Display -> User Display -> Nav data or Distance

Select [MENU] -> Display -> Speed display -> SOG or STW

Select [MENU] -> Service -> Print Header -> On

The figure consists of three screenshots from a marine electronic display system, illustrating the effect of the 'Units' setting.

- Left Screenshot (Nav data):** Shows a navigation data screen. The 'SOG' (Speed Over Ground) is displayed as '11.1 kt' and 'COG' (Course Over Ground) is '45.8'. A box labeled 'Nav data' points to these values.
- Middle Screenshot (Distance):** Shows a distance display screen. The 'DISTANCE' is displayed as '123.4 nm'. A box labeled 'Distance' points to this value.
- Right Screenshot (Print Header):** Shows a print header for a received message. The 'Distance' field is circled and labeled 'Print Header', showing a value of '760.5nm'. Other fields include 'Received JUL 13 2005 10:31:21' and 'Position 32° 32' N 129° 07' E'.



## 2.4 Setting of Display menu

Differences in the Display menu between the program Ver-01.02 and Ver-02.01 are the presence of the item “User Select Station & Msg”.

- Ver-01.02 → Included in the NAVTEX menu.
- Ver-02.01 → Included in the System menu.

### 1. Scrolling (Slow/Fast/Skip to \$\$)

This is the setting of the scroll amount when the [↑] or [↓] key is held down while a message is displayed. When key pressing is stopped, scrolling stops.

#### **Slow**

The screen is scrolled line by line while the key is held down.

#### **Fast**

The screen is scrolled by half a page while the key is held down.

#### **Skip to \$\$**

The screen is skipped to the mark “\$\$” of a continue mark in a received message of U.S. National Weather Service.

### 2. Font Size (Small/Medium/Large)

The font size of the text display of a received message is changed.

When “Small” is selected, 38 characters are included in one line, 33 characters in “Medium” setting, and 19 characters in “Large” setting.

### 3. Time Display (24hour/12hour)

Select “12H” or “24H” for the time display type. The items reflecting the time display are as follows. This is not applied to the time in the received message.

- 1) Receiving time display in the received message list.
- 2) Nav data display field
- 3) Received time of print header

#### **Related setting:**

- [MENU] -> System -> Time Offset
- [MENU] -> System -> Time Display
- [MENU] -> Display -> User Display
- [MENU] -> Service -> Print Header

**4. Date Display (MMM DD YYYY/DD MMM YYYY/YYYY MMM DD)**

This is the type of the date display setting. The items reflecting the date display are as follows. This is not applied to the date in the received message.

- 1) Received date display in the received message list display (except “Year” display).
- 2) Nav data display field
- 3) Received date of print header

**Related setting:**

- [MENU] -> Display -> User Display
- [MENU] -> Service -> Print Header

**5. User Display (Off/Nav Data/Distance)**

This is the setting whether or not to display the Nav data or Distance data at the bottom of the received message screen.

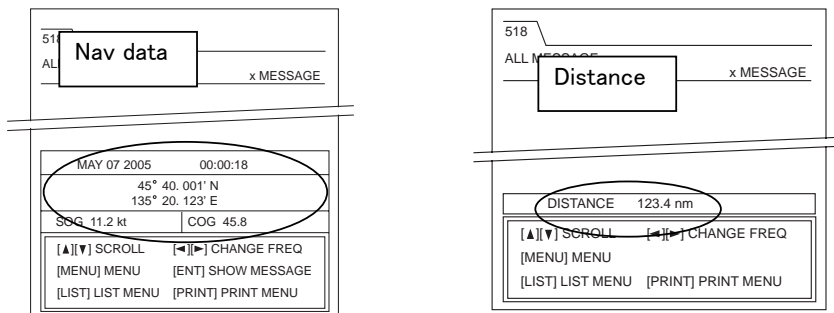

**Off**

Neither the Nav data nor the Distance data is displayed.

**Nav Data**

Displays L/L (GNS > GGA > RMC > GLL), Date/Time (ZDA), Speed (SOG: VTG > VBW > RMC, STW: VHW > VBW), and Course (VTG > RMC).

**Distance**

The distance information displays the distance between the own ship position and the position information nearest to the own ship included in the message by calculation. This display is intended to offer information to a user so that the user can make a judgment as to whether the received message is relevant to the own ship based on the own ship position and the position information included in the received message.

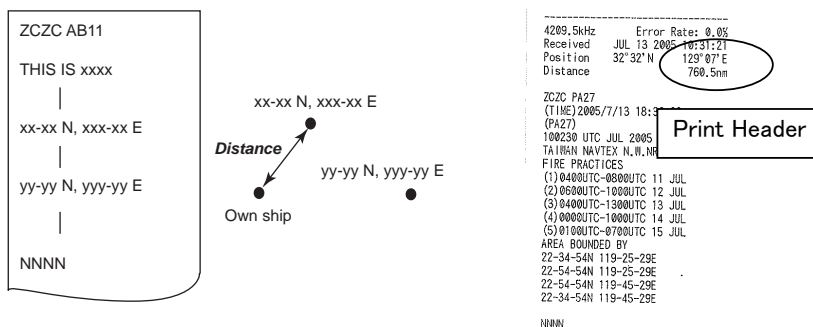

**Related setting:**

- [MENU] -> Display -> Time Display
- [MENU] -> Display -> Date Display
- [MENU] -> System -> Unit

**6. Speed Display**

**(SOG/STW)**

This is the setting of the ship speed type of the Nav data display at the bottom of the received message screen.

- SOG: Speed over ground (VTG > VBW > RMC)
- STW: Speed through the water (VHW > VBW)

**Related setting:**

- [MENU] -> Display -> User Display
- [MENU] -> System -> Unit

**7. Contrast**

**(5, 0 – 5)**

This is the contrast of the LCD screen setting.

This is set by the [←] and [→] keys with the bar graph displayed, not by numeric input. When the NX-700A/B is turned on again after this is set to “0”, the setting is automatically reset to the default “5”.

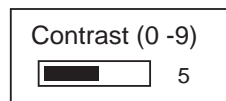

**8. User Select Station & Msg (Ver-02.01)**

This is the setting of the receiving station displayed in “User Selected Messages” which is displayed when the [LIST] key is pressed. See page 2-15 for details.

## 2.5 Setting of Service menu

The contents of the service menu are same for the programs Ver-01.02 and Ver-02.01.

### 1. INS Input Speed (4800/9600/19200/38400)

This is the setting of the bit rate for serial data input of the INS port J402 of NX-7001 unit. Select "4800" when the data is inputted by IEC61162-1 sentences from the GPS. When the INS is connected, set it according to the bit rate of the specifications of the INS.

#### *Related setting:*

Program Ver-01.02: Select "INS" in [MENU] -> NAVTEX -> Receive Mode.

Program Ver-02.01: Select "INS" in [MENU] -> NAVTEX -> Mask Mode.

### 2. INS Output Speed (4800/9600/19200/38400)

This is the setting of the bit rate for serial data output of the INS port J402 of NX-7001 unit. When the INS is connected, set it according to the bit rate of the specifications of the INS.

#### *Related setting:*

Program Ver-01.02: Select "INS" in [MENU] -> NAVTEX -> Receive Mode.

Program Ver-02.01: Select "Mask Mode" in [MENU] -> NAVTEX.

### 3. Print Header (On/Off)

This is the setting whether or not to print the header including the position information and time.

#### *Related setting:*

[MENU] -> Display -> Time Display

[MENU] -> Display -> Date Display

[MENU] -> System -> Unit

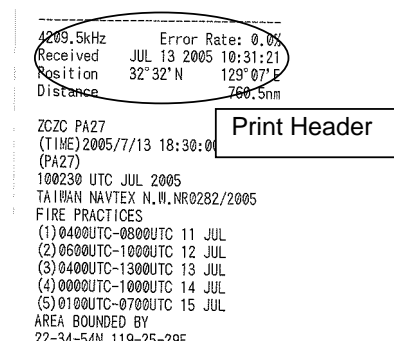

```

4209.5kHz      Error Rate: 0.0%
Received      JUL 13 2005 10:31:21
Position      32° 32' N   129° 07' E
Distance      700.5nm

ZCZC PA27
(TIME) 2005/7/13 18:30:00
(PA27)
100230 UTC JUL 2005
TAIWAN NAVTEX N.W. NR0282/2005
FIRE PRACTICES
(1) 0400UTC-0800UTC 11 JUL
(2) 0600UTC-1000UTC 12 JUL
(3) 0400UTC-1300UTC 13 JUL
(4) 0000UTC-1000UTC 14 JUL
(5) 0100UTC-0700UTC 15 JUL
AREA BOUNDED BY
??-??-??N ??-??-??E
  
```

#### 4. Edit Station List

The NAVTEX station list can be edited. Stations can also be added or deleted.

The maximum number of registered stations is 300 including the preset stations.

Auto mode is performed on the basis of the position and range data (service area) of this list.

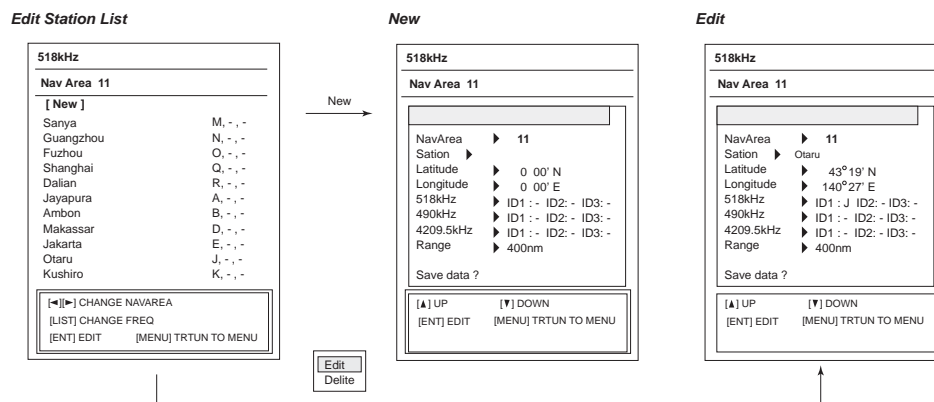

*Items to be edited are as follows:*

- 1) NAVAREA: 01 to16, EXT
- 2) Station : The station name is set by up to 18 characters.
- 3) Latitude : Set the latitude of the station between 0 deg. and 83 deg. N/S
- 4) Longitude : Set the longitude of the station between 0 deg. and 180 deg. E/W.
- 5) Range : Set the service area of the station between 1 and 999 nm.
- 6) 518kHz : Specify the ID of stations A to Z for ID1, ID2, and ID3, respectively.
- 7) 490kHz : Specify the ID of stations A to Z for ID1, ID2, and ID3, respectively
- 8) 4209.5kHz : Specify the ID of stations A to Z for ID1, ID2, and ID3, respectively.

When all the above settings is complete, put the cursor on “Save data?” and click [ENT] -> “Yes” to register the data.

#### 5. Default Setting

See page 7-15 for details.

#### 6. Test

See page 7-1 for details.

#### 7. Rcv Monitor

See page 7-10 for details.



## 2.6 Setting of Initialize-1 menu

The contents of the Service menu is same for the programs Ver-01.02 and Ver-02.01.

### 1. Delete All Msgs

See page 7-15 for details.

### 2. All Clear

See page 7-15 for details.

### 3. Demo Mode

(On/Off)

This is the setting intended for the purpose of demonstration at the exhibition, etc.  
The DEMO mode icon is displayed on the top of the screen to show that it is in the DEMO mode.

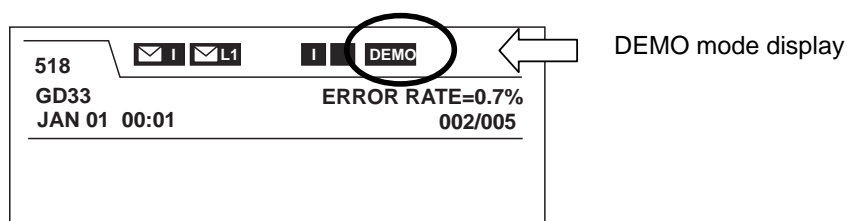

#### *In the DEMO mode,*

- 1) Even after the power is turned off, the DEMO mode is retained. The status of the mode is stored in the EEPROM.
- 2) When the DEMO mode is set to ON or OFF, all the received messages are cleared.
- 3) The position data and Date/Time data are not needed. The following data are set.
  - Position data : 12 deg. 34 min. 000N/123 deg. 45 min. 000
  - SOG/COG : 1.6 kt/56.0 deg, Automatically variable
  - Date /Time : 2005/JAN/01 00:00:00

### 4. System Test Results

See page 7-12 for details.

### 5. View Nav Data

See page 7-12 for details.

**6. ZCZC Check****(On/Off)**

This is the setting whether or not to receive a message when there is an error between ZCZC and the space after it. Always select "On".

- Off: When the error is not more than one character, the message is received.
- On: If there is an error, the message is not received.

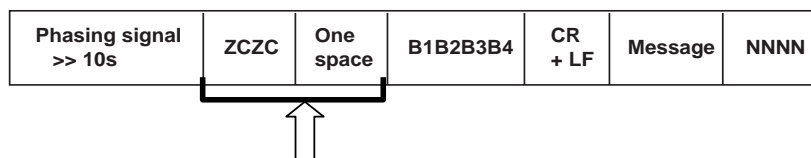

This section is checked.

**7. 00 Msg Priority****(B1>00>B2/00>B1>B2)**

This is the setting whether or not to receive a message when a message of "00" is received from a following station.

- 1) Station set as "Not Receive" in [MENU] -> NAVTEX -> Rcv Station & Msg.
- 2) Station set as "Not Receive" from the INS, or
- 3) Station not selected in Auto mode.
  - B1>00>B2: Not receive "00" message (for Russia Type approval)
  - 00>B1>B2: Receive "00" message (For IEC standard)

**Related setting:**

- Program Ver-02.01
  - [MENU] -> NAVTEX -> Mask Mode
  - [MENU] -> NAVTEX -> Auto Rcv Mask
  - [MENU] -> NAVTEX -> Local Channel
  - [MENU] -> NAVTEX -> Rcv Mask
- Program Ver-01.02
  - [MENU] -> NAVTEX -> Receiver Mode
  - [MENU] -> NAVTEX -> Local Channel
  - [MENU] -> NAVTEX -> Rcv Station

**8. Print Order****(Old->New/New->Old)**

This is the setting of the printing order of messages when a received message list is displayed and [PRINT] -> Print is executed.

- Old -> New: Printing is performed in the order starting from the oldest received message.
- New -> Old: Printing is performed in the order starting from the newest received message.

**Related setting:**

- [MENU] -> System -> Printer

### 9. Available Rcv Station List

This is the setting for displaying the list of receiving stations and message types that can be received by the setting in [MENU] -> NAVTEX -> Rcv Station & Msg or by the setting from the INS. The list also includes the display of stations automatically selected.

#### *Related setting:*

- Program Ver-01.02
  - [MENU] -> NAVTEX -> Receiver Mode
  - [MENU] -> NAVTEX -> Local Channel
  - [MENU] -> NAVTEX -> Rcv Station & Msg
- Program Ver-02.01
  - [MENU] -> NAVTEX -> Mask Mode
  - [MENU] -> NAVTEX -> Auto Rcv Mask
  - [MENU] -> NAVTEX -> Rcv Mask

### 10. Adjust Rx Unit

See page 7-13 for details.

### 11. Rx Test

See page 7-13 for details.

## 2.7 Setting of Initialize-2 menu

Differences in the Initialize 2 menu between the programs Ver-01.02 and Ver-02.01 are the presence of the setting “Russia Mode”.

- Ver-01.02 → Russia Mode is present.
- Ver-02.01 → Russia Mode is not present.

### 1. Sumless NMEA

(Ignore/Receive)

This is the setting for handling of sentences without checksum such as the position data. Basically, the sentence is “without checksum” in case of NMEA Ver-1.5, and “with checksum” in case of Ver-2.0 and IEC61162.

- Ignore : Does not accept Sentences without checksum.
- Receive : Accept Sentences without checksum.

### 2. ACK Command

(Ignore/Receive)

This is the setting for handling of the ACK sentence that stops an alarm from the INS when an alarm message is received. Always set this to “Receive”.

- Ignore : Does not accept the ACK sentence.
- Receive : Accept the ACK sentence.

#### **Related setting:**

##### Program Ver-02.01

- Select “On” in [MENU] -> System -> Warn Msg Alm.  
(ON/OFF for messages A, B and L. Always “ON” in case of message D)
- Select “INS” in [MENU] -> NAVTEX-> Mask Mode.

##### Program Ver-01.02

- Select “On” in [MENU] -> System -> Warn Msg Alm.  
(ON/OFF for messages A, B and L. Always “ON” in case of message D)
- Select “INS” in [MENU] -> NAVTEX-> Receiver Mode.

### 3. Serviceman Test

See page 7-5 for details.

### 4. Fill Memory

See page 7-14 for details.

### 5. Rcv Mon+NMEA Test

See page 7-14 for details.

### 6. DX RX Decision

(Soft/Hard)

This is the setting whether to judge as a character error when there is a difference in the status of DX and RX of the NAVTEX signal. Always set this to “Soft”.

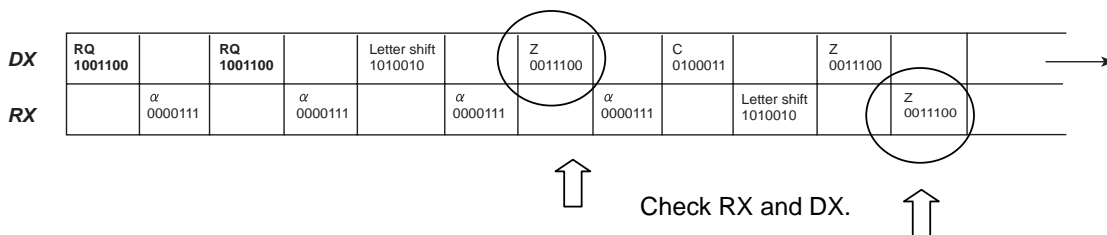

Status	Soft	Hard
DX and RX has the same 4B3Y code	OK	OK
DX and RX has different 4B3Y code	ERROR	ERROR
4B3Y for one, and not 4B3Y for the other.	OK (Use 4B3Y)	ERROR
Not 4B3Y for neither of them.	ERROR	ERROR

### 7. CR LF Check

(On/Off)

This is the setting whether or not to check <CR> and <LF> following the header in the error check of the message header (ZCZC AB01). Always set this to “Off”.

When this is set to “On” and <CR> and <LF> following the header cannot be received (is not present), the message is not received.

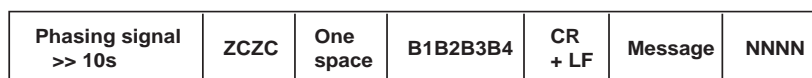

**8. Russia Mode****(On/Off)**

This item is added in the program Ver-02.01. When this is set to “On”, the functions are changed to comply with Russia Type approval.

Item	Russia Mode On (Russia)	Russia Mode Off (IEC)
Operation of the status display icon on the received message screen. [I]: Int'l Frq. [L1], [L2]: Local Frq.	1. Stand by for reception: The icon of set frequency is displayed. 2. In the course of receiving message: The icon of the receiving frequency blinks.	In the course of receiving message: The icon of the receiving frequency blinks.
Processing when “ZCZC ID” is detected before detecting “NNNN” in one message.	A part after “ZCZC ID” is regarded as another message and two messages are saved.	A part up till “NNNN” is detected is regarded as one message.
Time for determining the receiving error rate	Receiving stops if the error rate is 33 % or more in 5 sec.	Receiving stops if the error rate is 33 % or more in 30 sec.
Setting of Initialize1 -> 00 Msg Priority	Fixed to B1 > 00 > B2	B1 > 00 > B2, 00 > B1 > B2 selectable
Printing of message received at 490 kHz or 4209.5 kHz while a message is being received at 518 kHz.	Printing of message received at 490 kHz or 4209.5 kHz is deferred until receiving and printing of the message at 518 kHz is complete.	Printing is performed promptly.

## 2.8 Setting of printer $\mu$ TP-58E-FU

### 2.8.1 Default setting of DIP SW

Do not change the configuration of DIP switches for setting the printer operation.

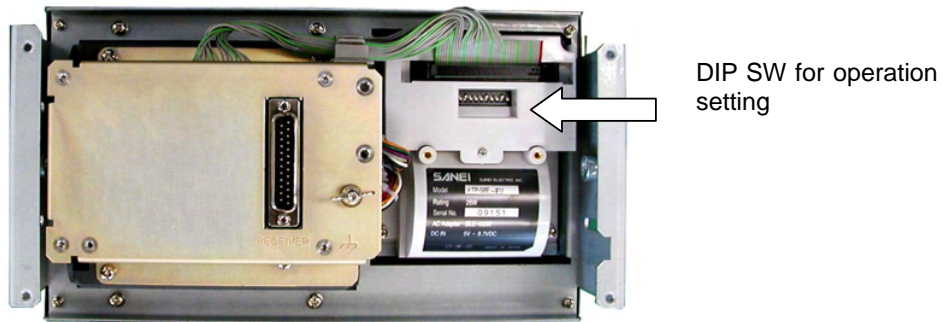

Fig. 2.8.1 DIP SW

Table 2.8.1 Default setting of DIP switches

	DIP SW Pin No.									
	1	2	3	4	5	6	7	8	9	10
Setting	OFF	ON	OFF	OFF	OFF	ON	OFF	OFF	ON	OFF

### 2.8.2 Switch operation

Table 2.8.2 Functions of DIP switches

DIP SW Pin No.	Function	OFF	ON
1 to 4	Communication method	See Table 2.8.3.	
5	Bit length	8 bits	7 bits
6	Control method	RTS/CTS	Xon/Xoff
7, 8	Command mode	See Table 2.8.4.	
9	Upright/ Inverted printing	Upright printing	Inverted printing
10	Test pin	Normal mode	Setting disabled

Table 2.8.3 Functions of DIP switches

Input method	Baud rate	Parity	DIP SW Pin No.			
			1	2	3	4
Serial	38400	None	OFF	OFF	OFF	OFF
	19200		ON	OFF	OFF	OFF
	9600		OFF	ON	OFF	OFF
	4800		ON	ON	OFF	OFF
	2400		OFF	OFF	ON	OFF
	38400	Odd	ON	OFF	ON	OFF
	19200		OFF	ON	ON	OFF
	9600		ON	ON	ON	OFF
	4800		OFF	OFF	OFF	ON
	2400		ON	OFF	OFF	ON
	38400	Even	OFF	ON	OFF	ON
	19200		ON	ON	OFF	ON
	9600		OFF	OFF	ON	ON
	4800		ON	OFF	ON	ON
	2400		OFF	ON	ON	ON
Parallel			ON	ON	ON	ON

Table 2.8.4 Functions of DIP switches

Command mode	DIP SW Pin No.	
	7	8
Mode 1 (20 digits)	ON	ON
Mode 2 (24 digits)	OFF	ON
Mode 3 (32 digits)	OFF	OFF
HEX dump mode	ON	OFF



# Chapter 3. Parts Location

## 3.1 NX-700A



Fig. 3.1.1 Front view



Fig. 3.1.2 Rear view

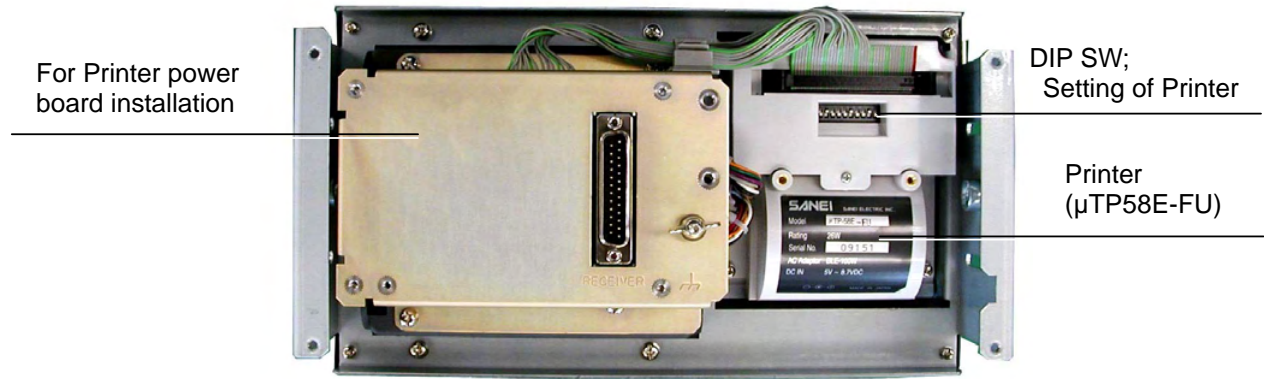

Fig. 3.1.3 Rear cover removed

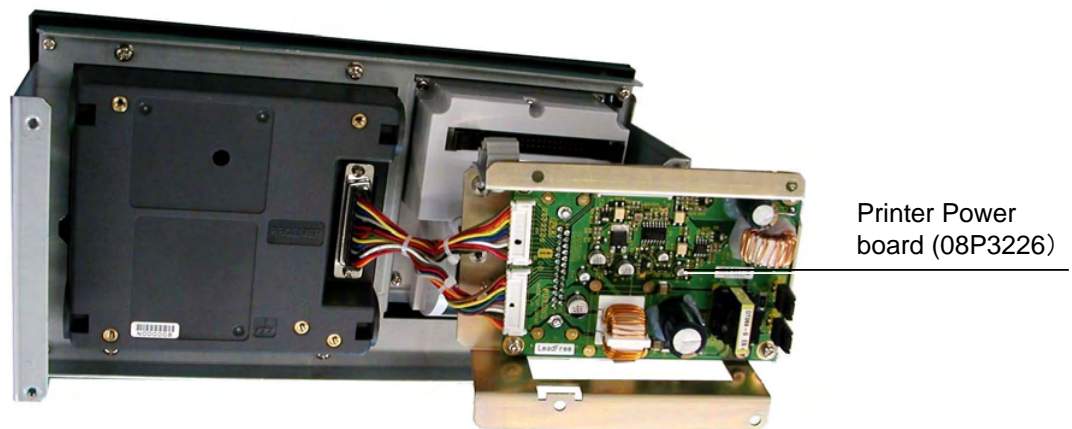

Fig. 3.1.4 Printer Power board

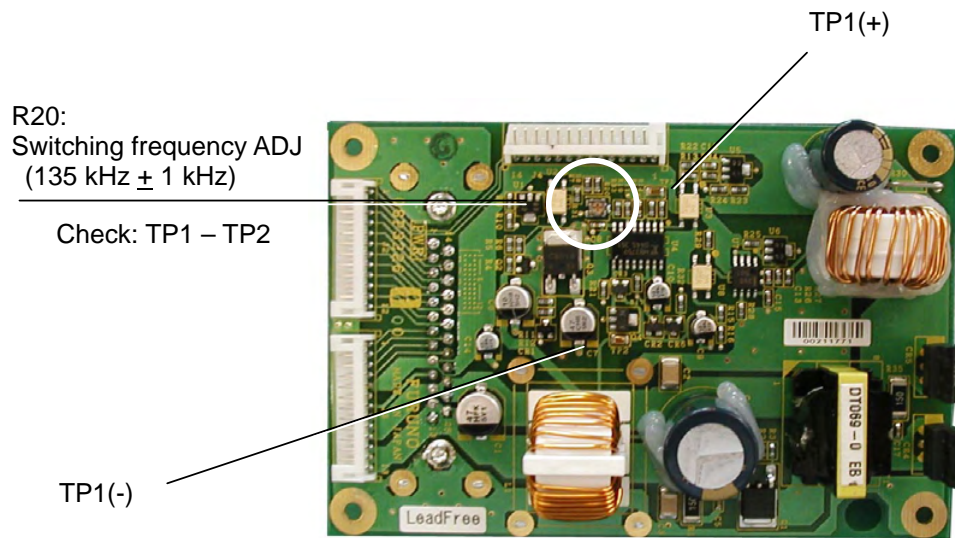

Fig. 3.1.5 PWR (Printer Power board): 08P3226, side-A

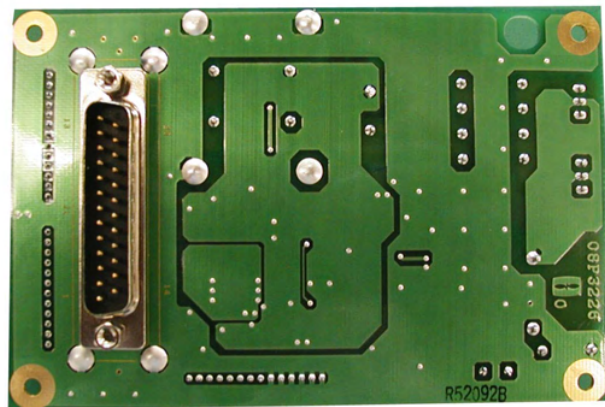

Fig. 3.1.6 PWR (Printer Power board): 08P3226, side-B





## 3.2 NX-700B



Fig. 3.2.1 Front view



Fig. 3.2.2 Rear view and Side view

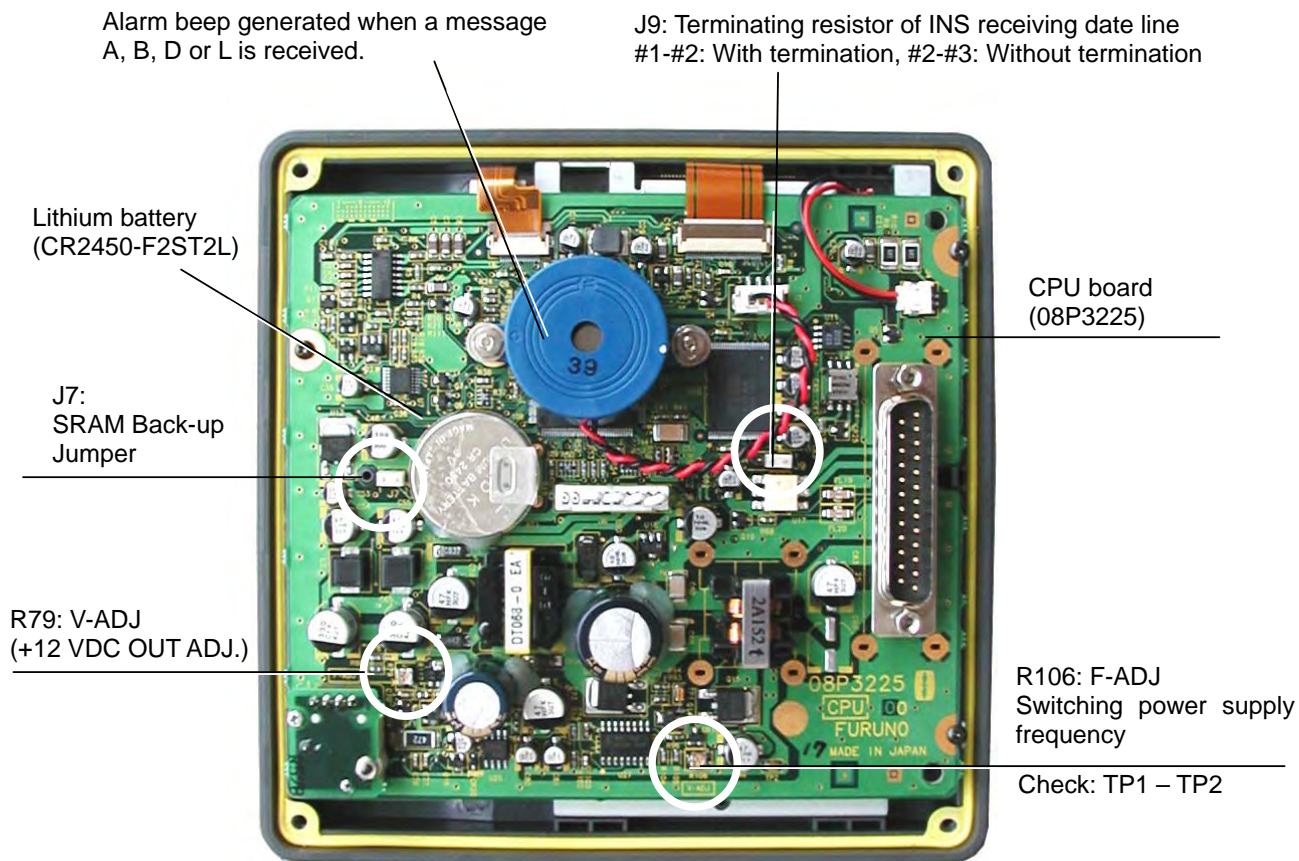

Fig. 3.2.3 NX-700B Rear panel removed

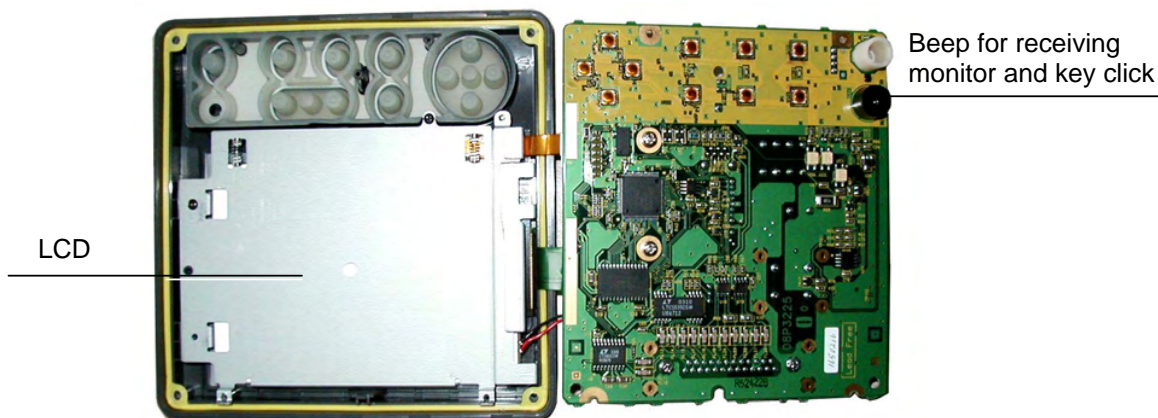

Fig. 3.2.4 CPU board removed

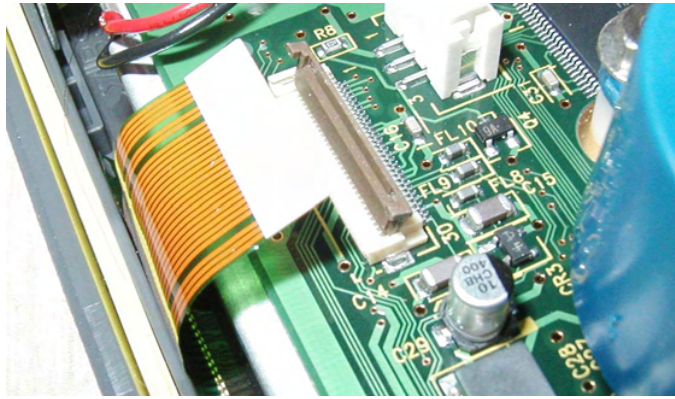

Fig. 3.2.5 J2 disconnected

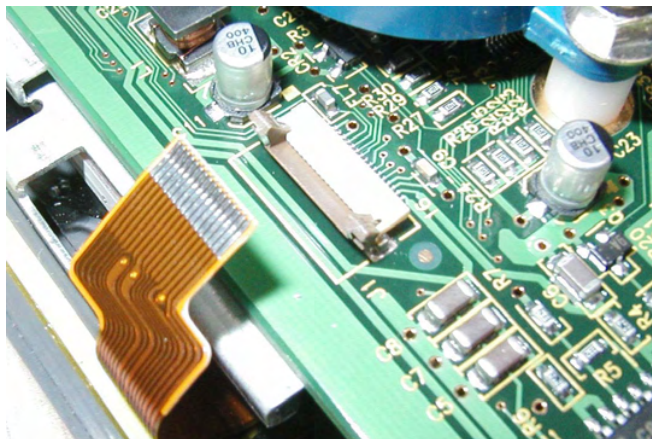

Fig. 3.2.6 J1 disconnected



### 3.3 Receiver unit: NX-7001

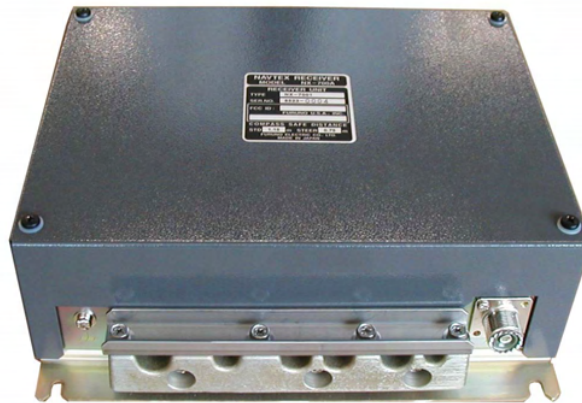

Fig. 3.3.1 Receiver unit

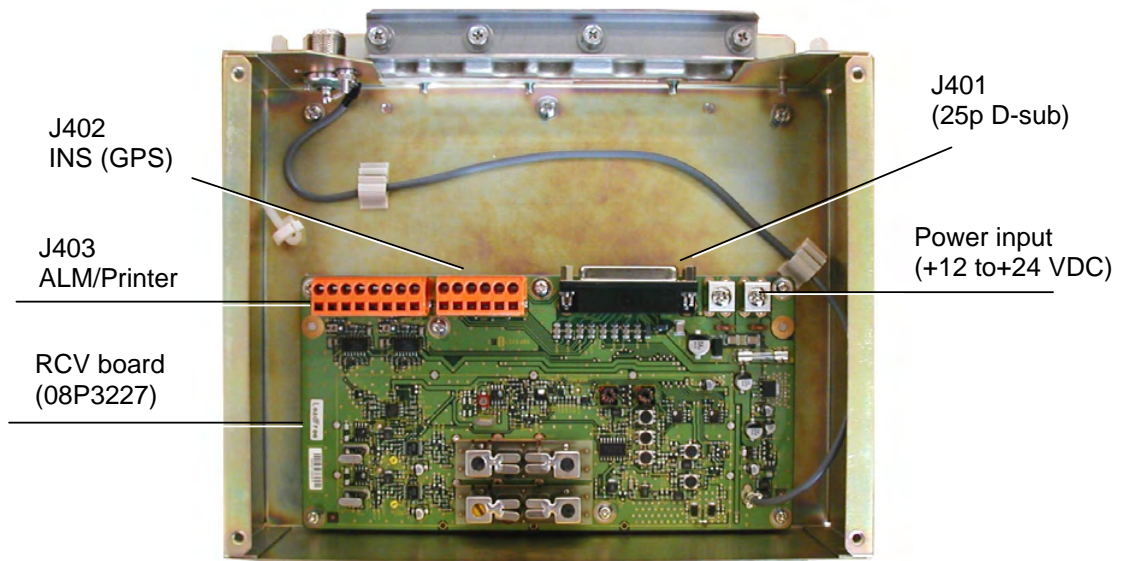

Fig. 3.3.2 Receiver unit cover removed



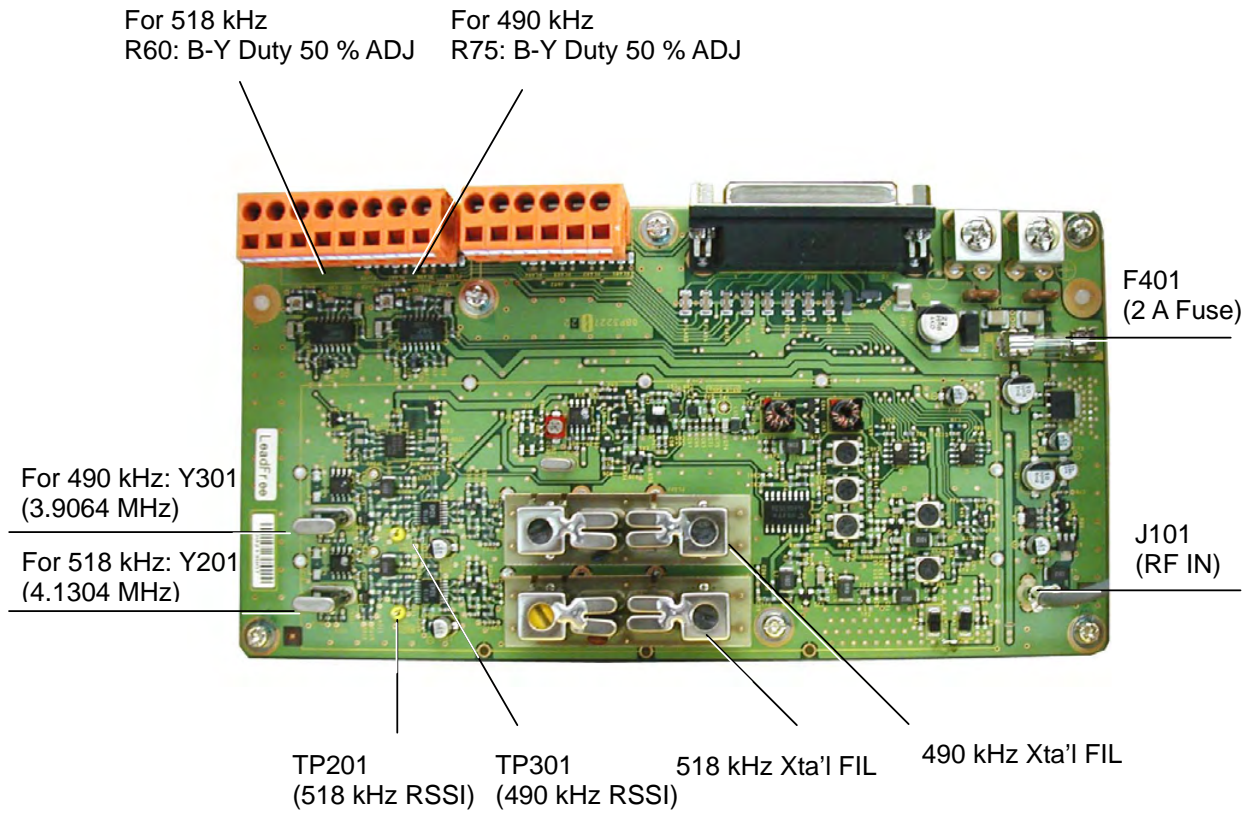

Fig. 3.3.3 RCV board: 08P3227

### 3.4 Antenna unit: NX-7H

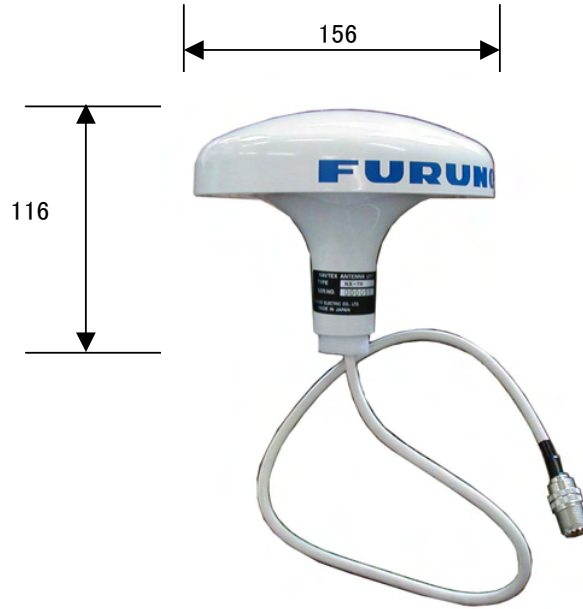

Fig. 3.4.1 NX-7H

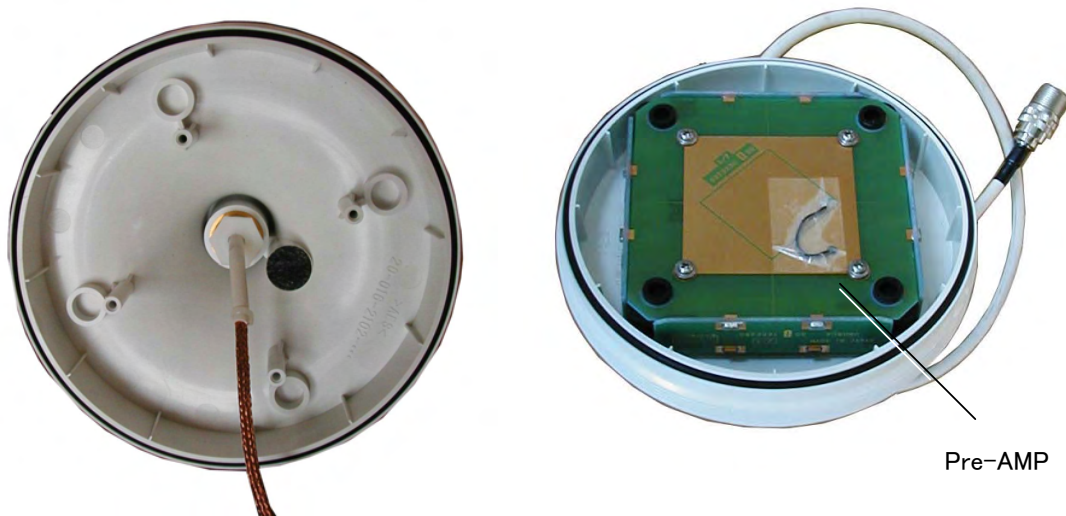

Fig. 3.4.2 Upper cover removed

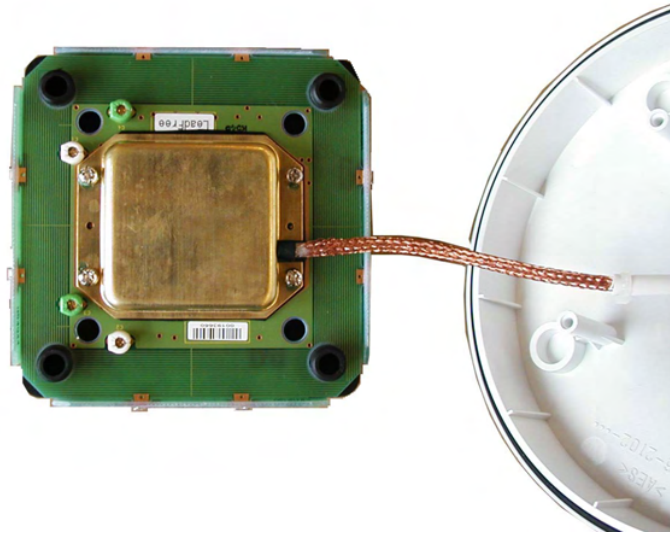

Fig. 3.4.3 Pre-AMP unit

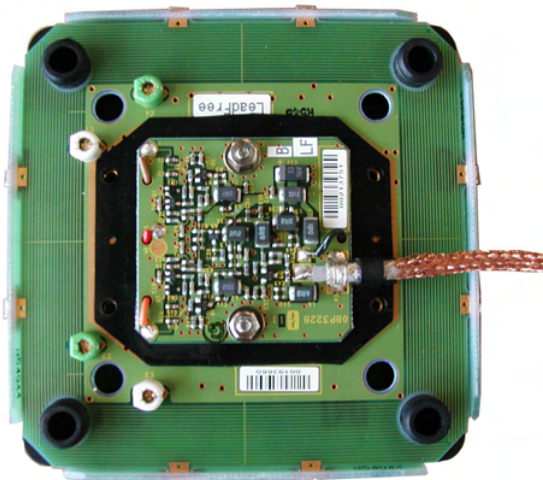

Fig. 3.4.4 Shield cover of Pre-AMP unit removed

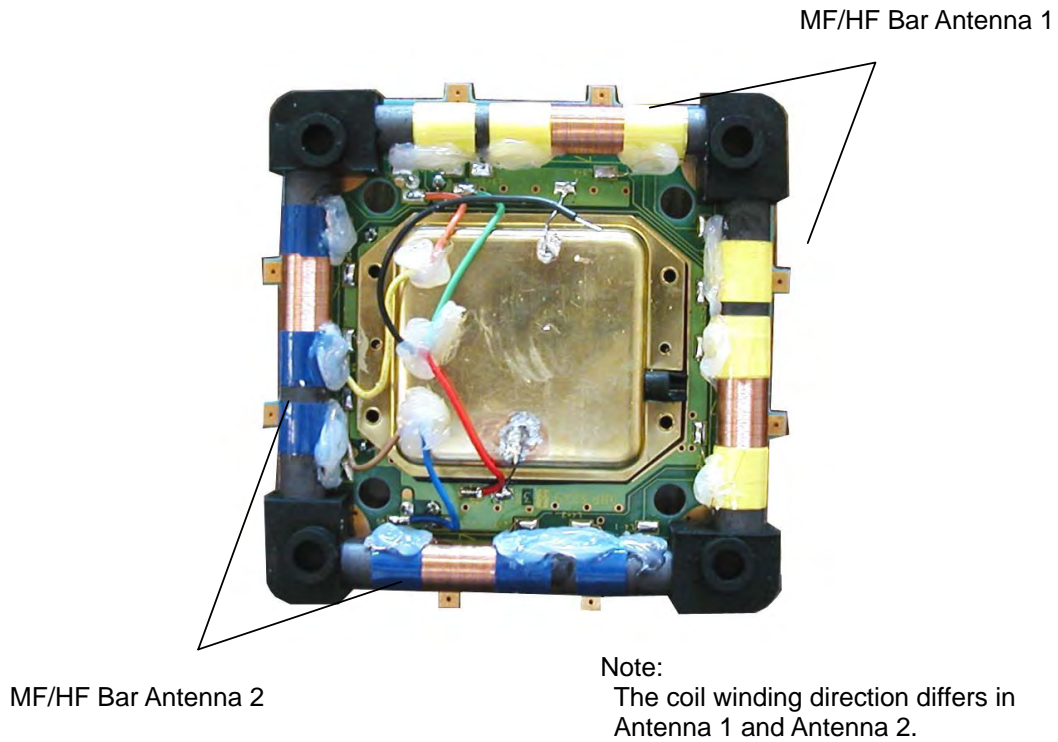

Fig. 3.4.5 Pre-AMP removed, and Bar Antenna

# Chapter 4. Menu Tree

The menu tree differs according to the program versions.

- Ver-01.02 : Comply with IEC Standard
- Ver-02.01 : Comply with Russian type approval

## 4.1 User Menu Tree

### 4.1.1 Program Ver-01.02

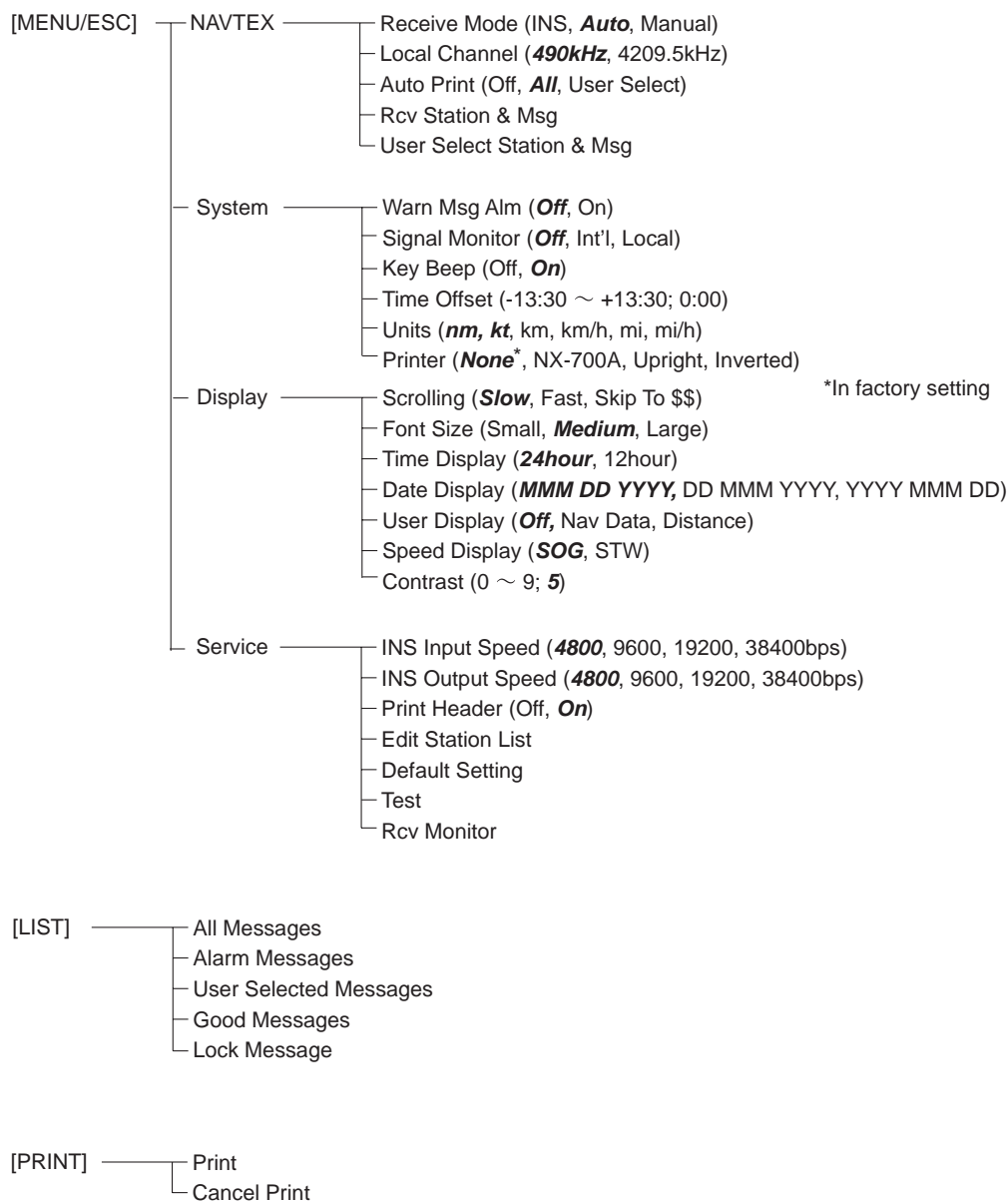

## 4.1.2 Program Ver-02.01

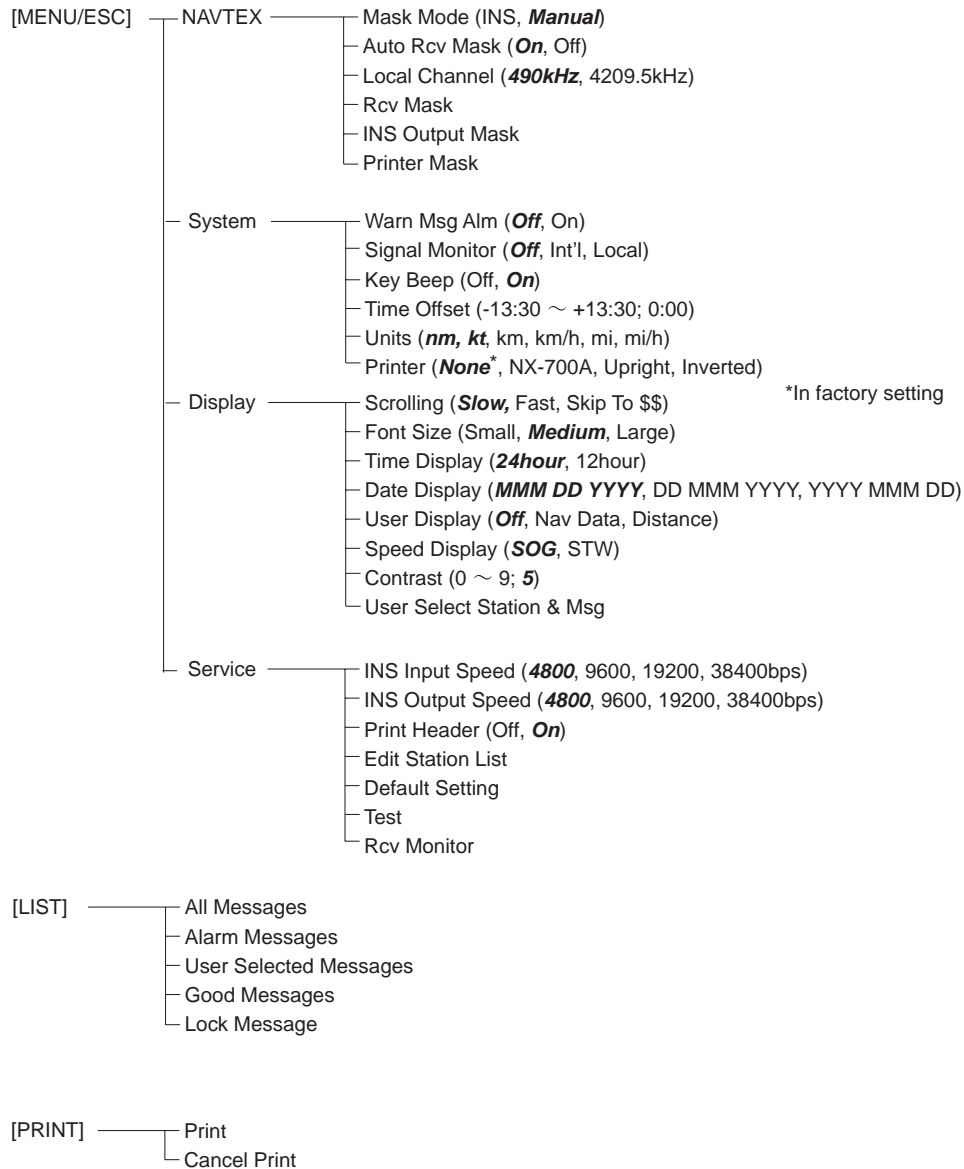

## 4.2 Initialize1, 2 Menu Tree

### 4.2.1 Program Ver-01.02

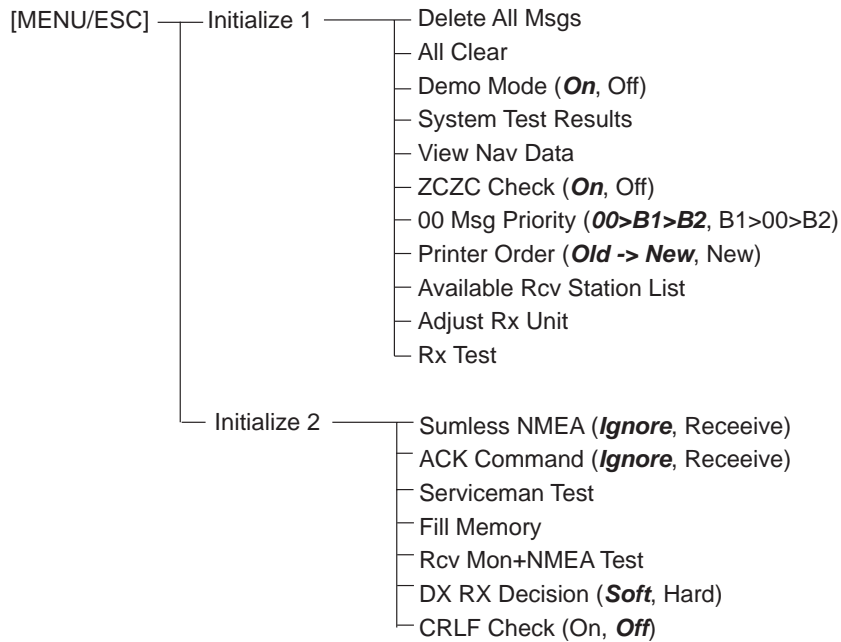

### 4.2.2 Program Ver-02.01

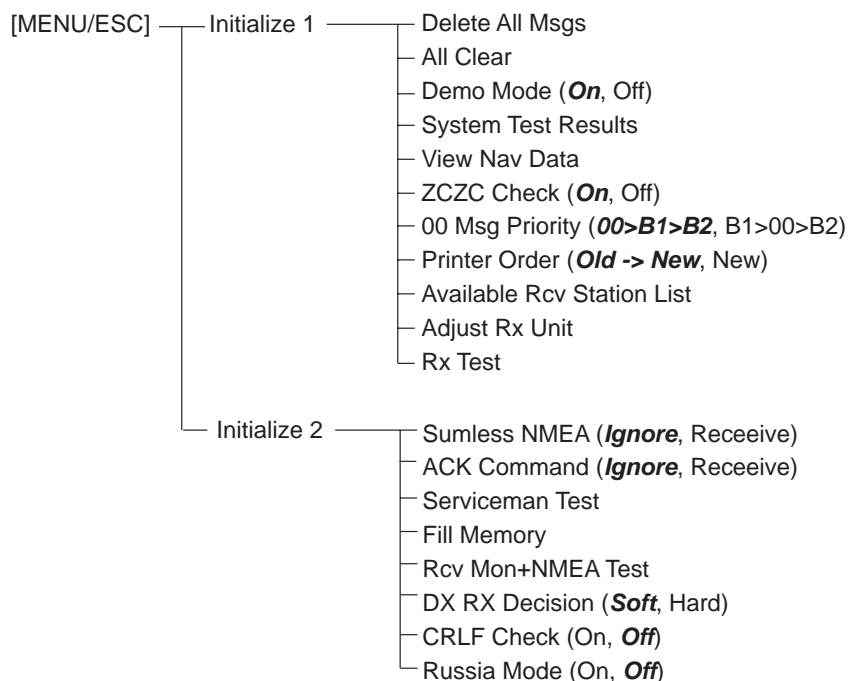

# Chapter 5. Block Description

## 5.1 Configuration

NX-700A and NX-700B are dedicated NAVTEX receiver which can simultaneously receive two frequencies, and it is comprised of an Antenna unit, a Receiver unit and a Display unit. The Antenna unit NX-7H uses a magnetic-field type antenna.

There are two types of display units:

- NX-700A: LCD display unit (NX-700B) + printer incorporated ( $\mu$ TP-58-FU) + printer power supply
- NX-700B: only LCD display unit (NX-700B)

### 5.1.1 NX-700A

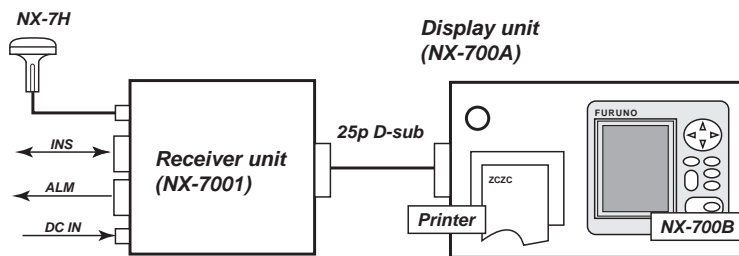

Fig. 5.1.1 Configuration of NX-700A

### 5.1.2 NX-700B

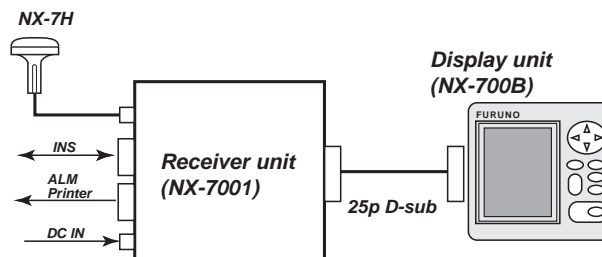

Fig. 5.1.2 Configuration of NX-700B



## 5.2 Connection

### 5.2.1 Overview of connection

#### 1. NX-700A

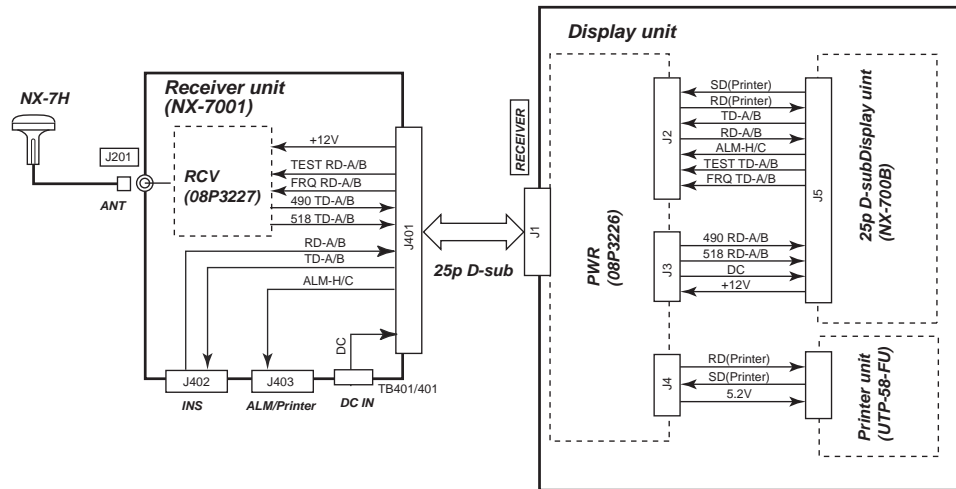

Fig. 5.2.1 Connection of NX-700A

#### 2. NX-700B

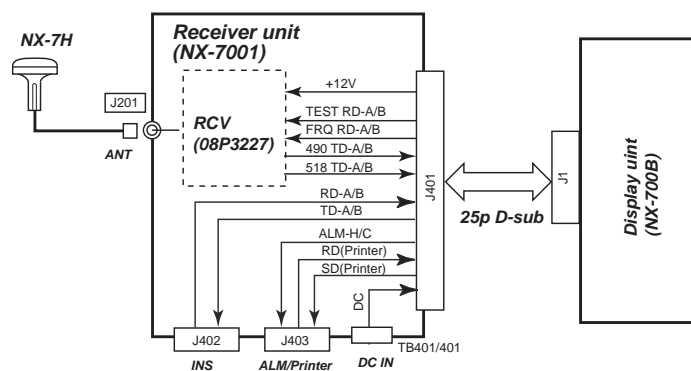

Fig. 5.2.2 Connection of NX-700B

### 3. Overview of boards

#### ***RCV (08P3227)***

The RCV board is incorporated in the Receiver unit.

NAVTEX signals are received at 518 kHz, 490 kHz or 4209.5 kHz. It is converted to FSK signal at 1700 Hz  $\pm$  85 Hz: BY signals of 0 and 1. And then, and sends them to the Display unit via RS-485.

#### ***PWR (08P3226)***

The PWR board is incorporated in the Display unit NX-700A (printer incorporating type) to supply power to the printer. The board outputs power +5.2 VDC from the input power (+12 VDC to +24 VDC).

#### ***CPU (08P3225)***

The CPU board is incorporated in the LCD display unit (NX-700B). The board is comprised as follows.

- CPU block (system control, handling NAVTEX signals: decodes BY signals sent from the RCV board, makes them up as received messages, and displays and stores them.)
- power supply block

#### ***Printer ( $\mu$ TP58E-FU)***

The printer is a serial printer of the NX-700A (Printer-incorporating type).

## 5.2.2 Input/output specifications

### 1. Receiver unit

Table 5.2.1 Specifications of Input/Output of Receiver unit

Pin No.	Signal	IN/OUT	Specifications
<b><i>J402 (I/O: WAGO terminal)</i></b>			
1	TD-A	OUT	IEC61162-1/2: RS-485 (INS Data output)
2	TD-B		
3	GND ISO		
4	RD-A	IN	IEC61162-1/2: RS-485 (GPS data/ INS Data input)
5	RD-B		
6	FG		
<b><i>J403 (I/O: WAGO terminal)</i></b>			
1	Alarm-H	OUT	Photo MOS relay contact output for external alarm (50 VDC / 0.5 A max.)
2	Alarm-C		
3	FG		
4	SD	OUT	RS-232C external printer signal (For NX-700B only, NC signal for NX-700A)
5	RD	IN	
6, 7	FG		
8	NC		

<b>J401 (25p D-sub connector)</b>			
1	SD	IN	RS-232C external printer signal (For NX-700B only, NC signal for NX-700A)
14	RD	OUT	
2	TD-A	IN	IEC61162-1/2: RS-485 (INS Data output)
15	TD-B		
3	RD-A	OUT	IEC61162-1/2: RS-485 (GPS data/INS Data input)
16	RD-B		
4	Alarm-H	IN	Photo MOS relay contact output for external alarm (50 VDC / 0.5 A max.)
17	Alarm-C		
5	TEST TD-A	OUT	RS-485
18	TEST TD-B		
6	FRQ TD-A	OUT	RS-485
19	FRQ TD-B		
7	490 RD-A	IN	RS-485
20	490 RD-B		
8	518 RD-A	IN	RS-485
21	518 RD-B		
9	+12 VDC	IN	
22	0 V		
10	GND ISO		
23, 11, 24	DC +	OUT	+12 VDC to +24 VDC
12, 25, 13	DC -		

## 2. Display unit: NX-700A/B

The specifications of the input/output of [RECEIVER] port of the Display unit: NX-700A incorporating a printer and the [RECEIVER] port of NX-700B including LCD unit alone are same, although SD/RD signals of #1 and #14 pins of the [RECEIVER] port on NX-700A are not connected.

Table 5.2.2 Specifications of Input/Output of Display unit

Pin No.	Signal	IN/OUT	Specifications
1	SD	OUT	RS-232C external printer signal (For NX-700B only, NC signal for NX-700A)
14	RD	IN	
2	TD-A	OUT	IEC61162-1/2: RS-485 (INS Data output)
15	TD-B		
3	RD-A	IN	IEC61162-1/2: RS-485 (GPS data/INS Data input)
16	RD-B		
4	Alarm-H	OUT	PhotoMOS relay contact output for external alarm (50 VDC / 0.5 A max.)
17	Alarm-C		
5	TEST TD-A	OUT	RS-485
18	TEST TD-B		
6	FRQ TD-A	OUT	RS-485
19	FRQ TD-B		
7	490 RD-A	IN	RS-485
20	490 RD-B		
8	518 RD-A	IN	RS-485

21	518 RD-B		
9	+12 VDC	OUT	
22	0 V		
10	GND ISO		
23, 11, 24	DC +	IN	+12 VDC to +24VDC
12, 25, 13	DC -		

### 3. Printer: $\mu$ TP-58E-FU

Pin No.	Signal	IN/OUT	Function
1	STROBE	IN	Data read (Active Low)
2 - 9	DATA 0 - 7	IN	Data High: 1, Data Low: 0
10	ACK	OUT	Data input acknowledge signal (Active Low)
11	BUSY	OUT	Shows that data read is disabled
12	PE	OUT	Shows paper run-out
13	SEL OUT	OUT	High in online status
14	ERROR	OUT	Shows error occurrence (Active Low)
15	RESET	IN	Reset signal (Enabled with Low for 20 msec. Active Low)
16	TxD	OUT	RS-232C data send
17	RxD	IN	RS-232C data receive
18	RTC	OUT	RS-232C request to send data
19	CTS	IN	RS-232C send enabled
20	NEAR A	OUT	Paper near end sensor anode (+)
21	NEAR C	IN	Paper near end sensor collector (+)
22	NEAR K		Paper near end sensor cathode (GND)
23	NEAR E		Paper near end sensor emitter (GND)
24	NEAR OUT	OUT	Paper near end signa
25	FEED IN	IN	Feed signal (Active Low)
26	FEED GND		Feed signal ground (GND)
27	SEL LED+	OUT	Power supply for SEL LED lighting (+)
28	SEL LED-	OUT	Power supply for SEL LED lighting (-)
29 - 34	V+		Power supply (+)
35 - 40	V-		Power supply (-)

## 5.3 Block Description

### 5.3.1 Receiver unit

#### 1. RCV (08P3227)

The receiving circuit is comprised of two systems to allow simultaneous reception at 518 kHz and 490 kHz or 4209.5 kHz.

NAVTEX signals received from the antenna are separated into two circuits: BPF, Q1 circuit and BPF Q4 circuit. Q1 circuit is a receiving circuit at 518 kHz and 490 kHz and the Q4 circuit is a receiving circuit at 4209.5 kHz.

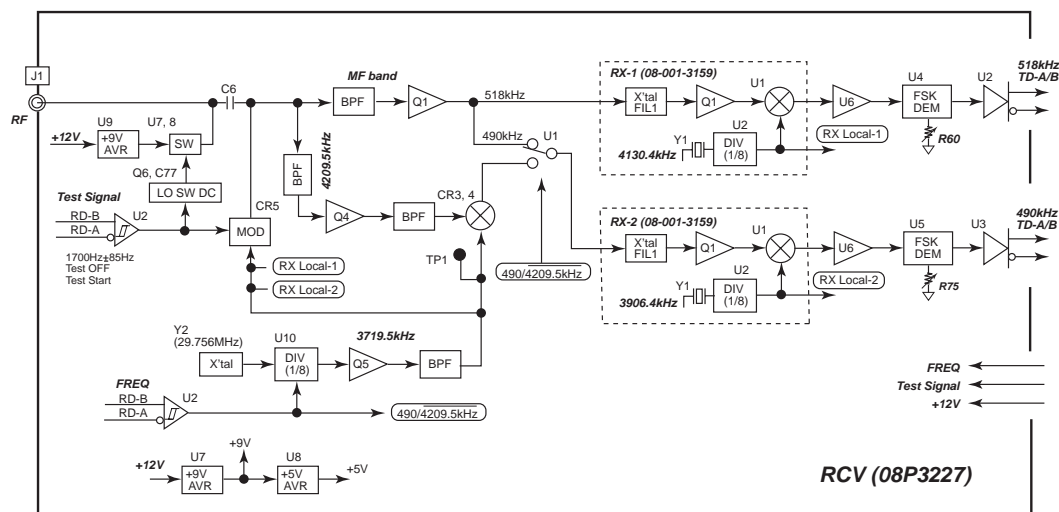

Fig. 5.3.1 Block Diagram of RCV board

#### Signals received at 518 kHz

Signals received at 518 kHz are inputted into RX1 circuit and converted into FSK signals of  $1700 \text{ Hz} \pm 85 \text{ Hz}$  at U1 of this circuit. The local oscillator frequency (516.3 kHz) at U1 is generated by dividing the frequency Y1 (4130.4 kHz) by 8 at U2.

$$(518 \text{ kHz} \pm 85 \text{ Hz}) - 516.3 \text{ kHz} = 1700 \text{ Hz} \pm 85 \text{ Hz}$$

The FSK signals are converted into 0 or 1 signal at U4 (PLL detection). R60 at U4 adjusts the signals by setting "Adjust Rx Unit" to "On" in "[MENU] -> Initialize1" so that the duty of U4 output signal (BY signal) is 50 %.

BY signals are converted into RS-485 signals at U2 and sent to the Display unit.

**Signals received at 490 kHz**

Signals received at 490 kHz are switched at U1, inputted into RX2 circuit and converted into FSK signals of  $1700 \text{ Hz} \pm 85 \text{ Hz}$  at U1 of this circuit. The local oscillator frequency (488.3 kHz) at U1 is generated by dividing the frequency Y1 (3906.5 kHz) by 8 at U2.

$$(518 \text{ kHz} \pm 85 \text{ Hz}) - 488.3 \text{ kHz} = 1700 \text{ Hz} \pm 85 \text{ Hz}$$

The FSK signals are converted into 0 and 1 signals at U5 (PLL detection). R75 at U5 adjusts the signals by setting “Adjust Rx Unit” to “On” in “[MENU] -> Initialize1” so that the duty of U5 output signal (BY signal) is 50 %. BY signals are converted into RS-485 signals at U3 and sent to the Display unit.

**Signals received at 4209.5 kHz**

Signals received at 4209.5 kHz are converted into 490 kHz at CR3 and 4. The local oscillator frequency of 3719.5 kHz inputted to CR3 and 4 is generated by dividing the frequency X'tal of 29.865 MHz by 8 at U10.

$$4209.5 \text{ kHz} - 3719.5 \text{ kHz} = 490 \text{ kHz}$$

Signals converted into 490 kHz are switched at U1 and inputted to RX2 circuit. The signal flow after that is the same as described above for signals received at 490 kHz.

**Receiving test**

In the receiving test, test signals ( $1700 \text{ Hz} \pm 85 \text{ Hz}$ , Test start, Test off) sent from the Display unit via RS-485 are received at U2.

To start the receiving test, turn on the LO SW DC signal by the Test start signal, turn off the power (+9 VDC) to the antenna, and shut off signals from the antenna and noises. Then  $1700 \text{ Hz} \pm 85 \text{ Hz}$  signal is modulated to AM at CR5.

The carrier frequency is a local oscillator signal from RX-1, RX-2 and 4209.5 kHz Local oscillator circuit. NAVTEX received signals are obtained from the component of AM- modulated signals. The figure below shows the spectrum of the test signal at 518 kHz.

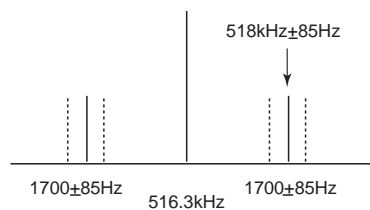

**Fig. 5.3.2 Spectrum of Test signal at 518 kHz**

**To switch to FREQ**

Switching to FREQ is performed by the FREQ signal (490 kHz, 4209.5 kHz) sent via RS-485 from the Display unit. This signal performs the control of switching circuit (U1) of receiving circuit at 490 kHz and 4209.5 kHz, and the control of local oscillator frequency 4209.5 kHz (U10).

## 5.3.2 Display unit

### 1. CPU board (08P3225)

The CPU board is comprised with CPU block and Power supply block.  
Main specifications of CPU block are shown below.

Table 5.3.1 Main specifications of CPU block

Item	Specifications
Set ID storage time	One year or more (After power OFF)
Number of stored IDs	200 x 2 channels
Number of stored messages	200 messages x 2 channels (100,000 characters x 2 channels)
LCD display unit	240 x 320 dots (5-inch LCD), message display: - 38 characters x 19 lines (Font size: Small) - 33 characters x 16 lines (Font size: Standard) - 19 characters x 9 lines (Font size: Large)
External input/output	- Output: IEC61162-1/2 (INS) - Input: IEC61162-1/2 (GPS, INS) - Output: Alarm (Normally open) - Input/output: Printer

#### ***CPU block***

The CPU displays received messages by converting BY signals of NAVTEX into 4B-3Y. And communication with the RCV board and the INS (Integrated Navigation System) is performed via RS-485.

U13 EEPROM stores setting values.

U10 SRAM can store up to 200,000 characters of received messages. The received messages are backed up by a battery BT1 (600 mAh). The life of the battery is 5 to 10 years depending on usage conditions. When the capacity of the back-up battery is reduced,  icon appears in the status field of the received message list screen. The popup window of "Battery Error" is also displayed. See page 7-20.

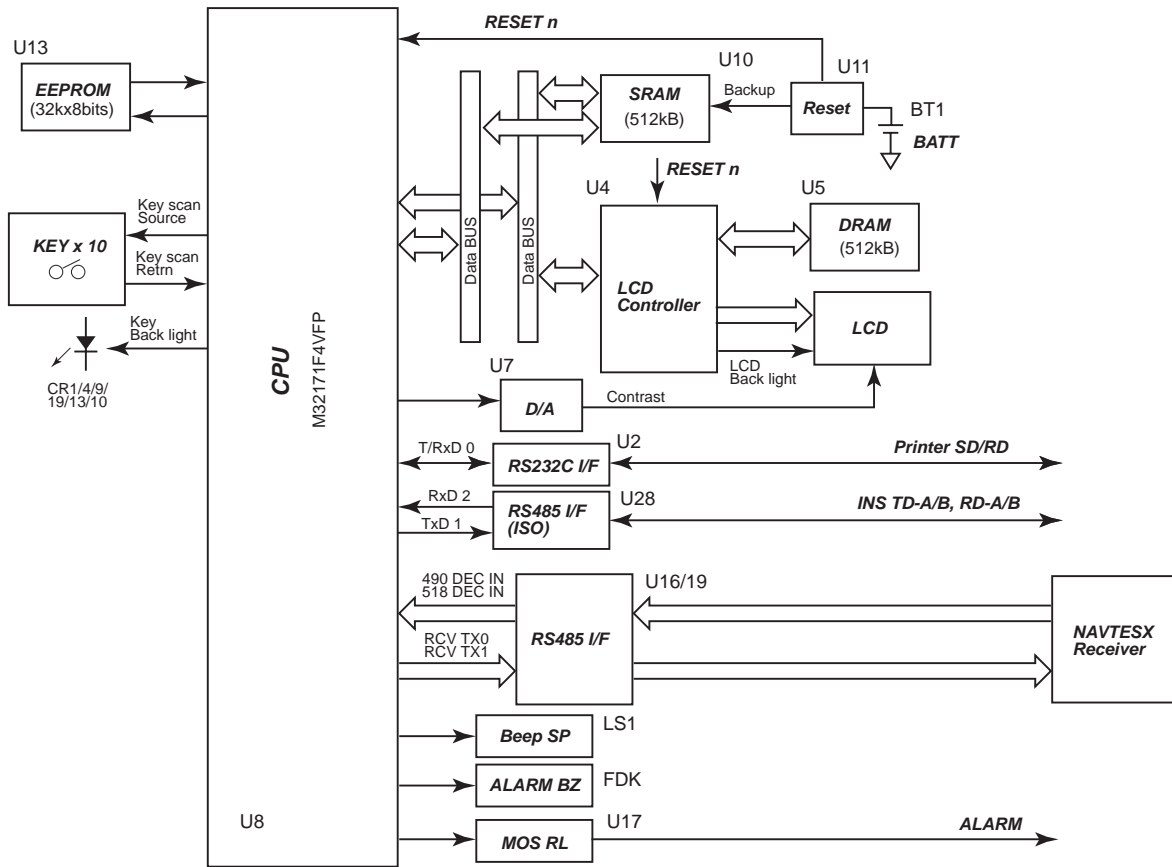

Fig. 5.3.3 Block Diagram: CPU block

Table 5.3.2 Memory contents

Memory		Memory description
ROM	ROM integrating U8	Program storage
SRAM	U10	All received messages and setup menus, work memory
DRAM	U5	Memory for display, work memory
CPU RAM	ROM integrating U8	CPU work memory
EEPROM	U13	When a battery for the SRAM (U10) back up is replaced, all the setup menus stored here are transferred to the SRAM. Setting data is updated every hour.



An alarm output is outputted with the contact signal: normally open when a message A, B, D or L is received. By the use of the photo MOS relay, the output circuit provides the maximum rated output of 50 VDC and 0.5 A.

The message A, B and L can be set to ON or OFF by the system setting. As for the message D, an alarm is always output when this message is received.

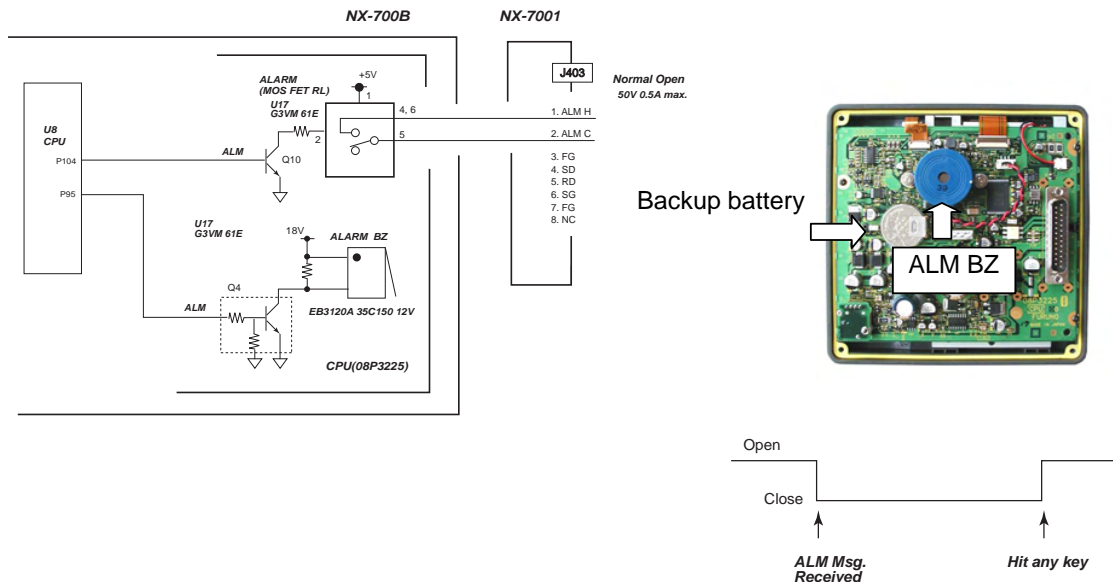

Fig. 5.3.4 Alarm circuit

**Power supply block**

The input voltage of +12 VDC to +24 VDC is converted to +18 VDC, +12 VDC, +5 VDC and +3.3 VDC on the switching power supply circuit. The main specifications are as follows.

Table 5.3.3 Specifications of Power supply block

Item	Specifications	Remarks
Input power supply voltage range	+10.8 VDC to +31.2 VDC	
Switching frequency	192 kHz $\pm$ 10 kHz	Adjusted at R106
Conversion efficiency	65 % or more (at max load)	
+12 VDC output	+12 VDC $\pm$ 0.6 V, 100~300 mA	Output adjusted at R79
+3.3 VDC output	+3.3 VDC $\pm$ 0.2 V, 50~200 mA	Not adjusted
+5 VDC output	+5 VDC $\pm$ 0.2 V, 50~150 mA	Not adjusted
+18 VDC output	+18 VDC $\pm$ 1 V, 0~80 mA	Not adjusted
Output protection	Over-current protection: 780 mA to 1300 mA	Detected at R71-73, 109 and 110
Input reverse connection protection circuit	Provided, Protected by fuse (F401: 2A at CR401 of the receiver unit.)	
Input low-voltage protection	Provided, Operated at +7 VDC to +9 VDC	Detected at U24
Input over-voltage protection	Provided, Operated at +34 VDC to +38 VDC	Detected at U24
Power fail signal output	Detects power failure from +3.3 VDC output voltage. Time of 1.5 ms or more is assured for voltage drop from +3.3 VDC to +3.0 VDC.	

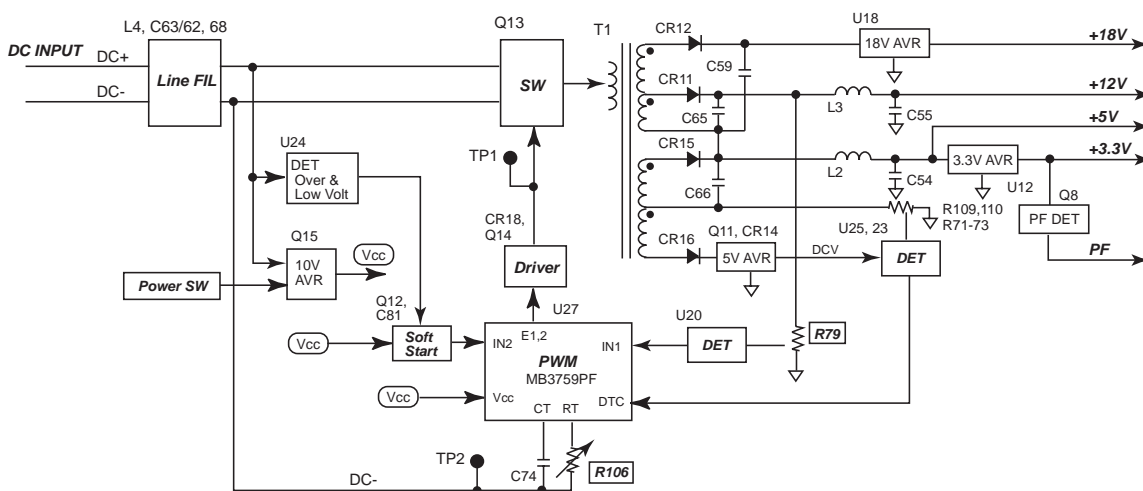

Fig. 5.3.5 Block Diagram: Power supply block

## 2. PWR (08P3226)

The PWR board is a power supply board for the printer integrated in the Display unit of the printer-incorporating type NX-700A. It outputs +5.2 VDC from the power supply input of +12 VDC to +24 VDC.

Main specifications are as shown in the table below.

Table 5.3.4 Specifications of PWR board

Item	Specifications	Remarks
Input power supply voltage range	+10.8 VDC to +31.2 VDC	
Switching frequency	135 kHz $\pm$ 1 kHz	Adjusted at R20
Conversion efficiency	65 % or more (at max load)	
+5.2 VDC output	+5.2 VDC $\pm$ 0.2 V, 50 mA to 1.5 A, Peak current 3 A	Not adjusted
Output protection	Over-current protection: 3.6 A to 6 A	Detected at R30
Input reverse connection protection circuit	Provided, Protected by fuse (F401: 2 A at CR401 of the Receiver unit.)	
Input low-voltage protection	Not provided (Stopped by input low-voltage protection of the Display unit)	
Input over-voltage protection	Not provided (Stopped by input over-voltage protection of the Display unit)	

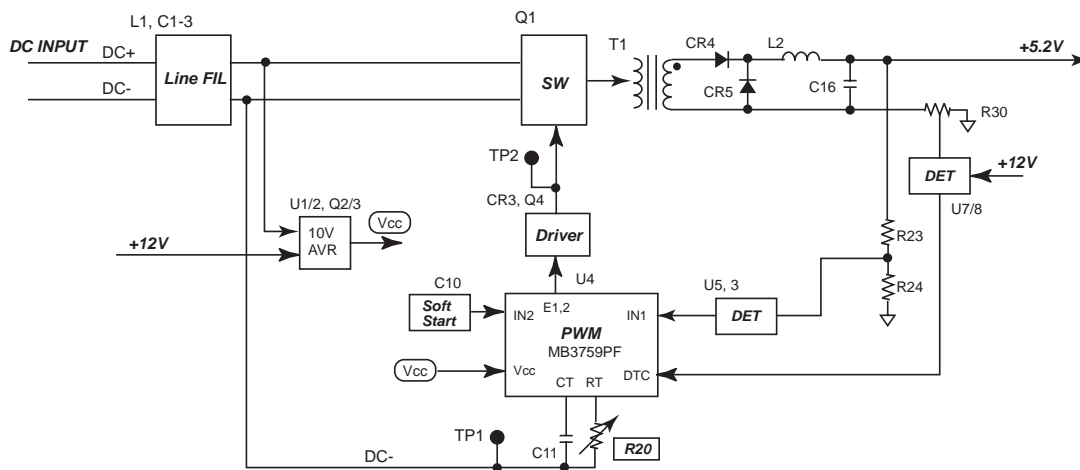

Fig. 5.3.6 Block Diagram of PWR board

### 3. Printer ( $\mu$ TP-58E-FU)

The Printer unit  $\mu$ TP-58E-FU prints data inputted in the serial RS-232C mode by the thermal line-dot method. The dot density is 8 dots/mm and the maximum printing speed is 20 mm/sec.

To connect a printer other than offered as the option, connect a printer meeting the following specifications.

- Number of printing digits : 32 characters or more /1 line
- Max printing speed : 1 line/3 sec. or less
- Xon/off control : Paper run-out control
- Communication format;
  - Communication speed : 9600 bps
  - Data length : 8 bit
  - Parity : None
  - Stop bit :1 bit

### 5.3.3 Antenna unit (NX-7H)

The antenna (NX-7H) is a non-directional, magnetic field type antenna. The gain of this unit is approximately 10 dB at 518 kHz and 490 kHz, and approximately 20 dB at 4209.5 kHz.

The circuit is comprised of two antenna coils and amplifier circuits for 4 MHz band and MF band.

The antenna coils are arranged on orthogonally-oriented X and Y axes. The phase difference of signals induced by them is 90 degrees. To obtain this phase difference, a signal is composed by shifting the phase of the signal from the X and Y axes by 45 degrees in the “45 deg. Phase shift” circuit. One end of the “45 deg. Phase shift” circuit is provided with the capacitor C13 and the other end with the resistor R23.

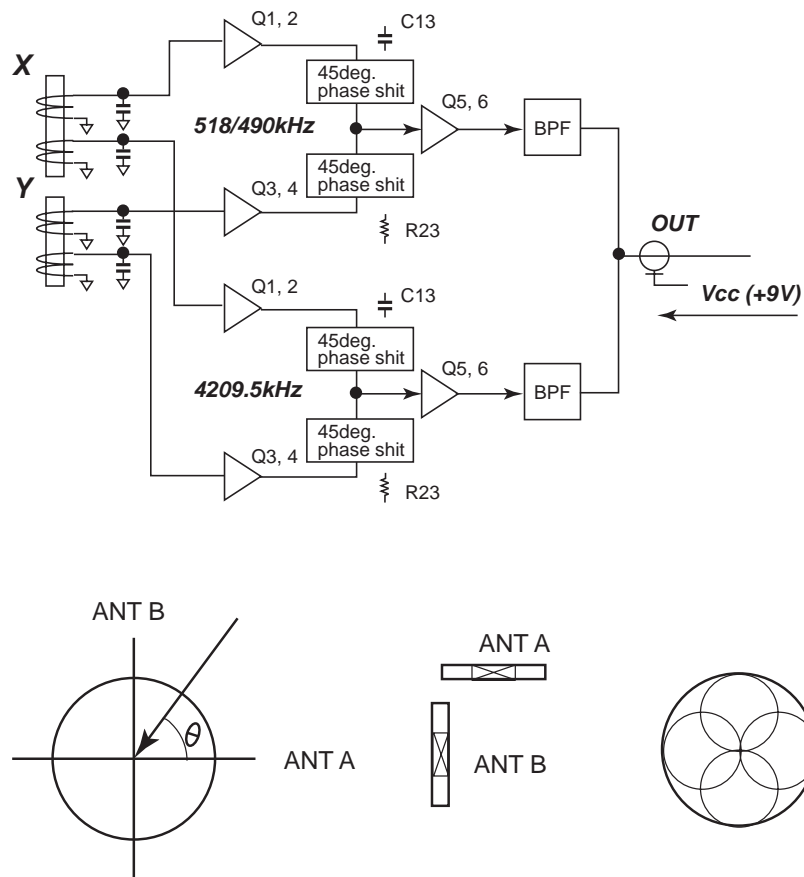

Fig. 5.3.7 Block Diagram of Antenna unit

**Reference;**

Letting the voltage magnitude ( $V_A$ ) induced in the antenna coil A in the direction of maximum sensitivity = "1",

$$V_A = \sin\theta$$

Letting the voltage magnitude ( $V_B$ ) induced in the antenna coil B in the direction of maximum sensitivity = "1",

$$V_B = \cos\theta$$

Letting the high-frequency voltage induced in the antenna coil A =  $V_A \sin\omega t$ , the high-frequency voltage induced in the antenna coil B =  $V_B \sin\omega t$  or  $-V_B \sin\omega t$ .

Hence the relation of voltage induced in the antenna coil A and B is in-phase or reversed phase. If the high-frequency voltage induced in the antenna coil A or B is given a phase difference by 90 degrees,

$$V_A \sin\omega t$$

$$V_B \sin(\omega t + \pi/2) = V_B \cos\omega t$$

When the two formulas above are added,

$$V_A \sin\omega t + V_B \cos\omega t$$

$$= \sin\theta \sin\omega t + \cos\theta \cos\omega t$$

$$= \cos(\omega t - \theta)$$

In consequence, "1" in the direction of maximum sensitivity is obtained for the magnitude of combined induced voltages regardless of the receiving direction of radio wave.

# Chapter 6. Program Update

## 6.1 Overview

### 6.1.1 Program file

The table below shows the information on files for updating the program. The file size is given for the purpose of reference.

Table 6.1.1 List of Program files

File	Size	Type
Load.bin	7 KB	BIN file
nx700.bin	469 KB	BIN file
Up.bat	1 KB	Batch file (For updating program)
Uppg.exe	60 KB	Application

#### *Batch file*

UP.BAT

```
uppg load.bin nx700.bin 0 0 200 0
```

### 6.1.2 Notices

1. The program update port is connected to #1 (SD), #14 (RD) and #22 (GND) of the [RECEIVER] port of NX-700B. The port is configured as RS-232C for electric specifications.
2. When the serial port on the PC side is specified as “other than [COM-1]”, rewrite the batch file or change the selection of the COM port to [COM-1] on the PC side.
3. “Communication setting” of the serial port on the PC is not needed. When a program is updated, it is automatically set from “Uppg.exe”.
  - While the program is booted: speed is 9600 bps,
  - When program updating : speed is 57.6 kbps.

The protocol is as follows.

- Format: Data bit: 8, Stop bit: 1, Parity bit: None
- Flow control: None

### 6.1.3 Preparation

#### 1. Connection

Prepare the cable to be connected between the serial port of the PC and the [RECEIVER] port of the Display unit as shown below.

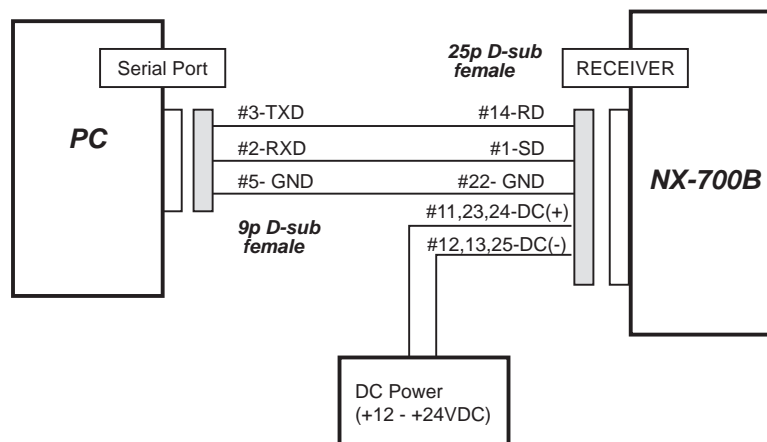
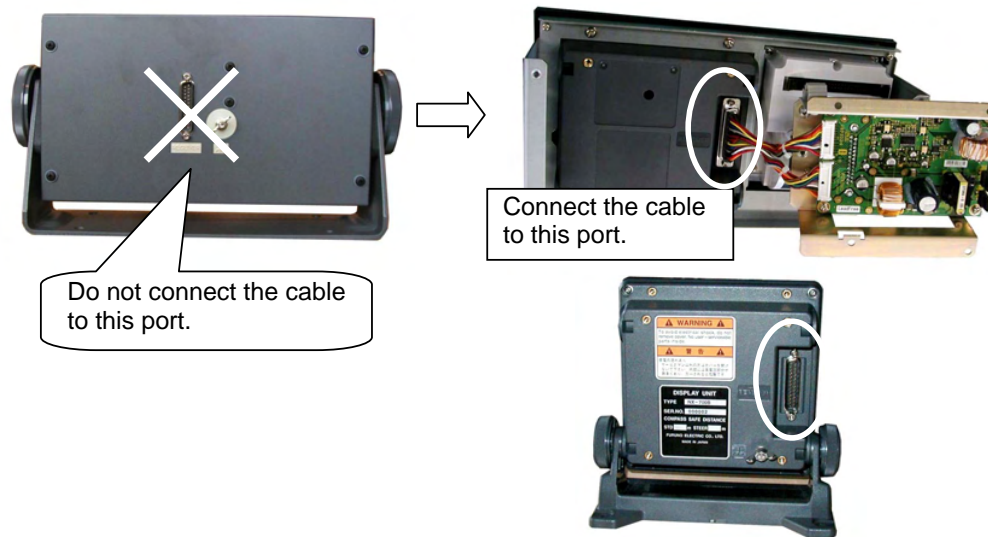

Fig. 6.1.1 Connection for updating NX-700 Program



## 2. Procedure for rewriting COM port of batch file

- 1) Open [Control Panel] -> [System] -> [Device Manager] and check the COM port number on “USB - RS-232C Driver”.
- 2) Select a batch file to be updated and open the batch file by clicking [File] -> “Edition”.
- 3) Enter the COM port number of the PC at the end of the text of the batch file. For instance, if the COM port is COM3, enter “3” after the half-size space.

```
uppg load.bin nx700.bin 0 0 200 0
uppg load.bin nx700.bin 0 0 200 0_3
```

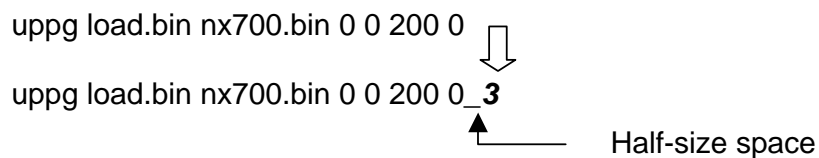

Half-size space

- 4) Select [File] -> “Save” to save the edited text.  
When the edited text cannot be saved, right-click the icon of the batch file, and select [Property] -> [General] Tag. Check that there is no check mark in the “Read only” box for the [Attribute].

## 6.2 Procedure for updating

### 6.2.1 Procedure

1. Turn off NX-700B (LCD display unit).
2. Open the NX-700 program folder.
3. Double click the batch file “UP”.

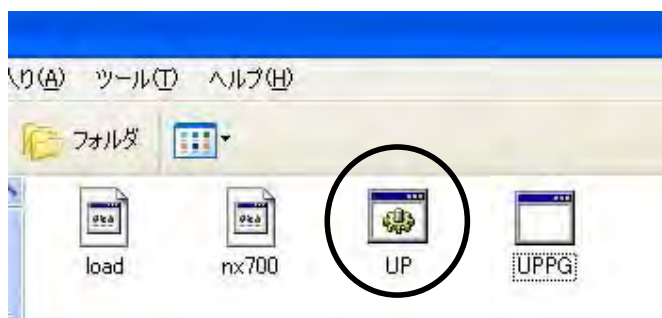

4. When the DOS-prompt window appears and the message “TARGET POWER ON” is displayed, turn on NX-700.

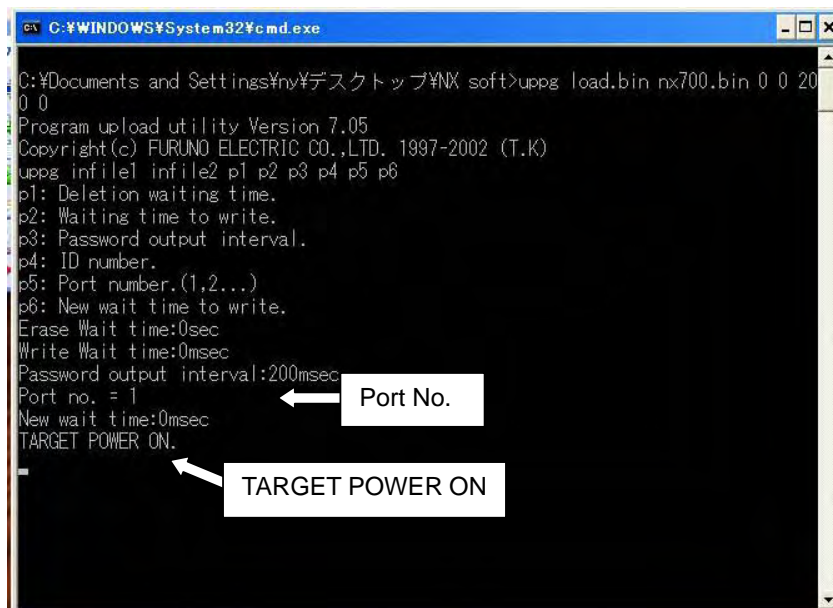

```
C:\WINDOWS\System32\cmd.exe
C:\Documents and Settings\%ny%\デスクトップ\NX soft\uppg load.bin nx700.bin 0 0 20
0 0
Program upload utility Version 7.05
Copyright(c) FURUNO ELECTRIC CO.,LTD. 1997-2002 (T.K)
uppg infile1 infile2 p1 p2 p3 p4 p5 p6
p1: Deletion waiting time.
p2: Waiting time to write.
p3: Password output interval.
p4: ID number.
p5: Port number.(1,2...)
p6: New wait time to write.
Erase Wait time:0sec
Write Wait time:0msec
Password output interval:200msec
Port no. = 1
New wait time:0msec
TARGET POWER ON.
```

- The updating of the program is automatically started. While the program is being updated, nothing is displayed on the LCD.

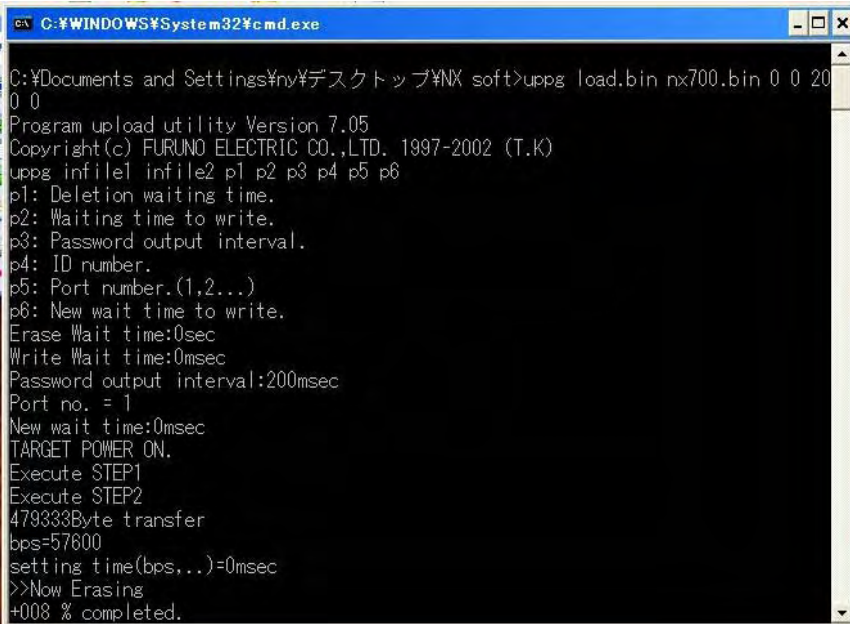

```
C:\WINDOWS\System32\cmd.exe
C:\Documents and Settings\%ny%\デスクトップ\NX soft>uppg load.bin nx700.bin 0 0 20
0 0
Program upload utility Version 7.05
Copyright(c) FURUNO ELECTRIC CO.,LTD. 1997-2002 (T.K)
uppg infile1 infile2 p1 p2 p3 p4 p5 p6
p1: Deletion waiting time.
p2: Waiting time to write.
p3: Password output interval.
p4: ID number.
p5: Port number.(1,2...)
p6: New wait time to write.
Erase Wait time:0sec
Write Wait time:0msec
Password output interval:200msec
Port no. = 1
New wait time:0msec
TARGET POWER ON.
Execute STEP1
Execute STEP2
479333Byte transfer
bps=57600
setting time(bps,..)=0msec
>>Now Erasing
+008 % completed.
```

- When updating is complete, the normal display appears on the LCD.  
The time for updating is 3 to 4 minutes.
- Turn off NX-700B once and return the connection as it was.

### 6.2.2 Check of program number

1. Hold down both the [+] and [-] keys of the DIM for over 5 seconds on a screen on which the popup display is not shown and the received message list or received messages are shown.

The Initialize1 and Initialize2 menus are added in the Menu list as shown below.

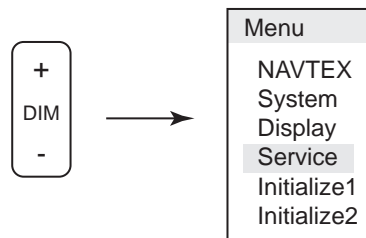

2. Select "Initialize 2" and execute "Serviceman Test".

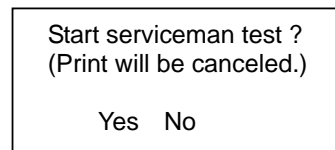

3. The Memory Test screen is displayed as below. Check the program number.

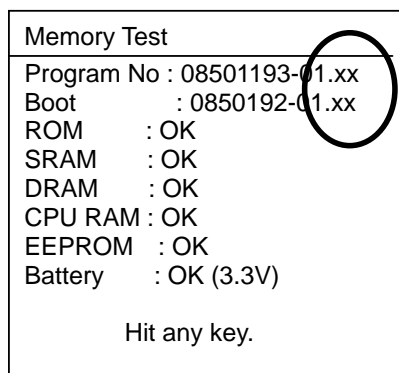

Detailed program version

**Note:**

The program number displayed in "[MENU] -> Service -> Test" is a version which complies with the requirements for the type approval.

4. When the program number is checked, turn off the power or continue "Serviceman Test" to the end according to the guidance on the screen.

# Chapter 7. Maintenance

## Call up the Initialize menu

The Initialize menu includes the Initialize1 and Initialize2 menus as option menus. These menus include special settings and items related to maintenance.

To call up these menus, hold down both [+] and [-] keys of the DIM for over 5 seconds on a screen on which the popup display is not shown and the received message list or received message is shown.

The Initialize1 and Initialize2 menus are added in the menu list as shown below.

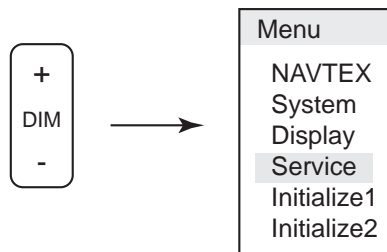

## 7.1 Self Test

It includes the Self Test performed by users and by service men and Self Test performed at the factory.

### 7.1.1 [MENU] -> Service -> Test

#### Procedure

1. Select [MENU] -> Service -> Test. Select "Yes" and press the [ENT] key. Then the test starts.

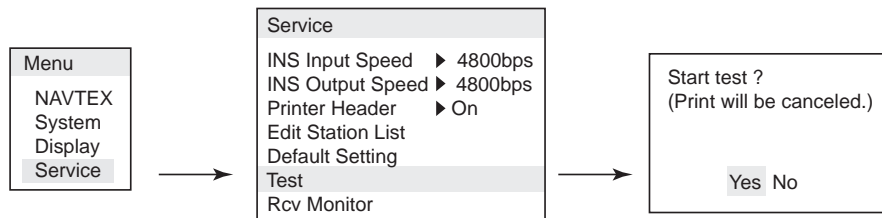

**Memory Test**

2. The memory test starts and the results of the test are shown.

Memory Test	
Program No :	08501193-01
Boot :	BOOTPGN-00
ROM :	OK
SRAM :	OK
DRAM :	OK
CPU RAM :	OK
EEPROM :	OK
Battery :	OK (3.3V)
Hit any key	

The contents of the checking are shown below.

**- Memory Test:**

Memory		Check on
ROM	built-in U8	Check on checksum
SRAM (Backup)	U10	Checked by Read/Write test
DRAM	U5	
CPU RAM	built-in U8	
EEPROM	U13	Checked by Read/Write test

**- Battery:**

When the test is performed, the voltage of the backup battery BT1 is checked and displayed. When a battery is newly installed, the voltage reads about +3.3 VDC. If the Status display field shows  mark, it shows that the battery voltage has dropped below +2.5 VDC. When this occurs, replace the battery with a new one. When the battery voltage goes down below +1.8 VDC, it becomes impossible to back up the storage memory of received messages (U10: SRAM). In this case, received messages are deleted when the power is turned off.

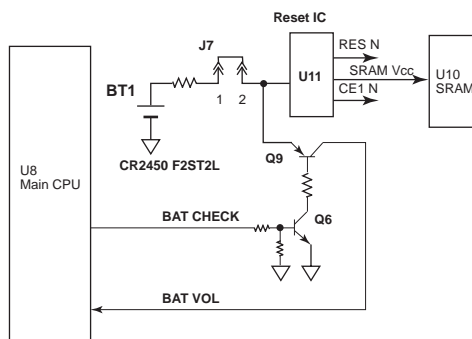
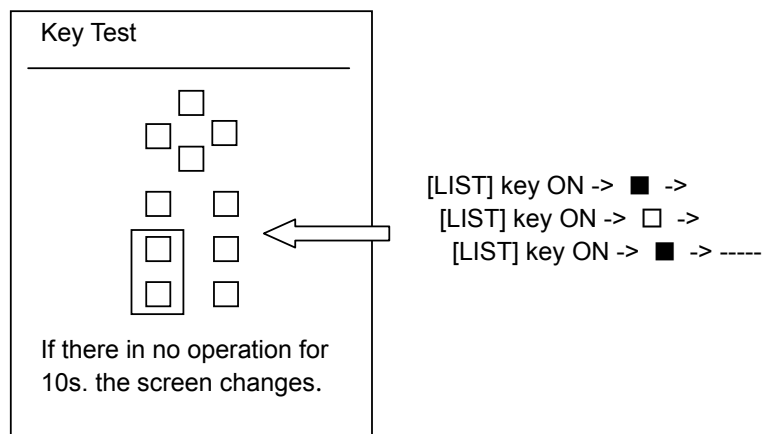

Fig. 7.1.1 Backup Battery voltage detection circuit

**Key Test**

3. When the Memory test is complete, press any key. The next Key Test starts. The screen shown below appears. A mark corresponding to the pressed key is highlighted every time a key is pressed. Check all the keys except the power key. When all the keys are highlighted, or when no key is pressed for 10 seconds, the next LCD Test is entered.

**LCD Test**

4. In the LCD test, the contrast of the screen automatically changes in 10 steps.

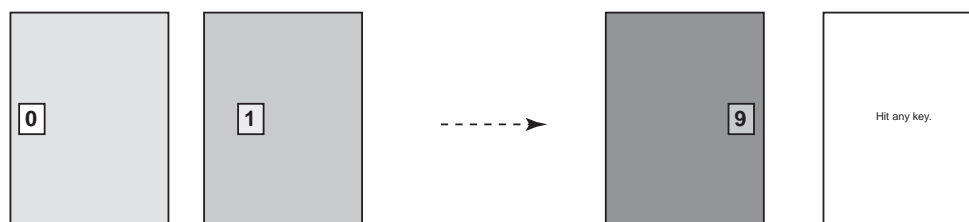
**RX Test**

5. When “Hit any key” is displayed, press any key. RX test starts.

RX Test is a reception test performed to check whether a signal is correctly received when a test signal is applied to the antenna input of the RCV board on NX-7001. The level of the test signal is approximately 10 dB $\mu$ V. During the reception test, received signals can be monitored even if “OFF” is selected in the setting of “[MENU] -> System Signal Monitor”.

The Int'l Rx Data is a test message received at 518 kHz. The Local Rx Data is a test message received at 490 kHz or 4209.5 kHz which is selected in “[MENU] -> NAVTEX -> Local Channel”.

***Judgment of OK or NG***

When the same message as the sent message is received, “OK” is displayed as the “Result”. If an error of even one character is included, the “Result” shows “NG”. The character of the error is marked with “\*”.

If the “Result” is “NG”, replace the RCV board. In the reception test, messages received at 518 kHz only can be printed by a printer.

<p><b>Rx Test</b></p> <hr/> <p><b>Tx Test</b></p> <p>ZCZC AZBB &lt;- T HIS IS AN I NTERNAL TES T MESSAGE.&lt;- ABCDEFGHIJKLMN OQRSTU V WXYZ,0123456789 - ? * \$ ! &amp; # ( ) /, ' = - ? + - &gt;   NNNN</p> <hr/> <p><b>Int'l Rx Data</b></p> <p>ZCZC AZBB &lt;- T HIS IS AN I NTERNAL TES T MESSAGE.&lt;- ABCDEFGHIJKLMN OQRSTU V WXYZ,0123456789 - ? * \$ ! &amp; # ( ) /, ' = - ? + - &gt;   NNNN</p> <hr/> <p><b>Local Rx Data</b></p> <p>ZCZC AZBB &lt;- T HIS IS AN I NTERNAL TES T MESSAGE.&lt;- ABCDEFGHIJKLMN OQRSTU V WXYZ,0123456789 - ? * \$ ! &amp; # ( ) /, ' = - ? + - &gt;   NNNN</p>	<p>-----</p> <p>518kHz                  Error Rate: 0.0%</p> <p>ZCZC AZ00 THIS IS AN INTERNAL TEST MESSAGE. ABCDEFGHIJKLMN OQRSTU V WXYZ 0123456789 - ? : \$ ! &amp; # ( ) / , ' = + NNNN</p> <p>-----</p>
<p>Int'l Result : OK Local Result : OK</p> <p>Hit any key</p>	

**Note:**

During Rx Test, the power supply (+9 VDC) to the pre-amp unit is turned off.

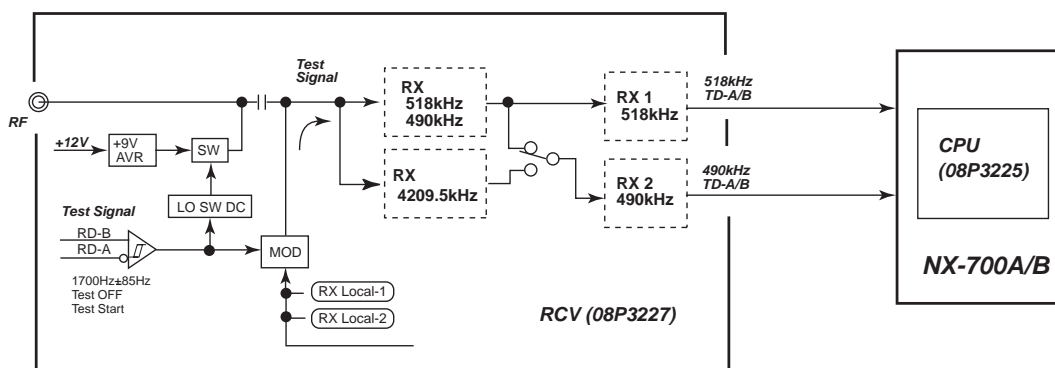

Fig. 7.1.2 Overview of Reception Test circuit

6. The screen returns to the Service menu screen when any key other than the power key is pressed or when there is no key operation for one minute or more.



## 7.1.2 [MENU] -> Initialize 2 -> Serviceman Test

### Procedure

1. Select “[MENU] -> Initialize 2” and execute “Serviceman Test”.

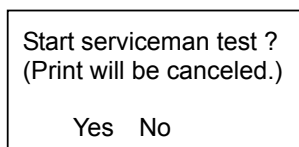

### Memory Test

2. The Memory Test screen is displayed as shown below. Check the program number, memory and voltage of backup battery.  
The screen shown here is the same as the Memory Test screen shown in page7-2, except the program number added with the detailed program version.

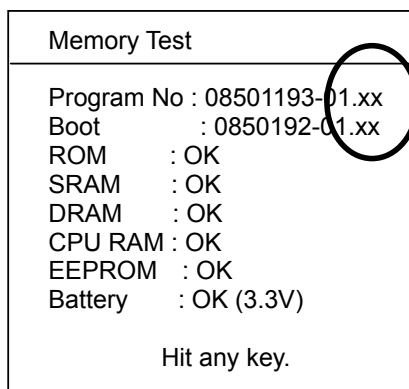

Detailed program version

Note:

The program number displayed in “[MENU] -> Service -> Test” is a version in conformity with the requirements for type approval.

### Key Test, LCD Test, RX Test

3. The Key Test, LCD Test and RX Test performed after the Memory Test are the same tests performed in the setting of “[MENU] -> Service -> Test”.  
See page 7-1 for details.

### 7.1.3 Factory Test

#### Procedure

1. Turn on the power while holding down both [+] and [-] keys of the DIM key. Keep holding down the keys until the Memory Test starts.

#### Memory Test

2. This Memory test is the same as the Memory Test performed in the setting of “[MENU] -> Initialize 2 -> Serviceman Test”. See page 7-5 for details.

#### Key Test

3. To proceed to the Key Test from the Memory Test, press any key.  
This test is the same test performed in the setting of “[MENU] -> Service -> Test”. See page 7-3 for details.

#### Loopback Test

4. To proceed to the Loopback Test from the Key Test, press all the keys or press no key for 10 seconds. Before starting this test, configure the jumpers according to the table below.

In the checking of the Printer and INS, a certain ASCII code is sent, and if it is received, the result is judged as OK. In the checking of Receiver 1 and Receiver 2, L and H levels are sent and if each level is detected, the result is judged as OK.

Loopback Test	
Printer	: OK
INS	: OK
Receiver1	: OK
Receiver2	: OK
Hit any key	

Table 7.1.1 Sections to be Jumpered for Loop-back Test

Test item	Model	Sections to be jumpered	
Printer	NX-700A	NX-700B : [RECEIVER]	#1 (SD) - #14 (RD)
	NX-700B	NX-7001: J403 (WAGO)	#4 (SD) - #5 (RD)
INS	NX-700A	NX-7001 J402 (WAGO)	#1 (TD A) - #4 (RD A)
	NX-700B		#2 (TD B) - #5 (RD B)
Receiver1	NX-700A	NX-700B : [RECEIVER]	#6 (FRQ TD-A) - #8 (518 RD-A)
	NX-700B		#19 (FRQ TD-B) - #21 (518 RD-B)
Receiver2	NX-700A	NX-700B : [RECEIVER]	#5 (TEST TD-A) - #7 (490 RD-A)
	NX-700B		#18 (TEST TD-B) - #20 (490 RD-B)

**Contrast Test**

5. In the Contrast Test, the contrast of the screen automatically changes in 10 levels as shown below. The screen displays the result of the contrast test last. If the test result is “Pass”, press the [ENT] key three times, and if the result is “Fail”, press the [PRINT] key three times to proceed to the next Dimmer Test.

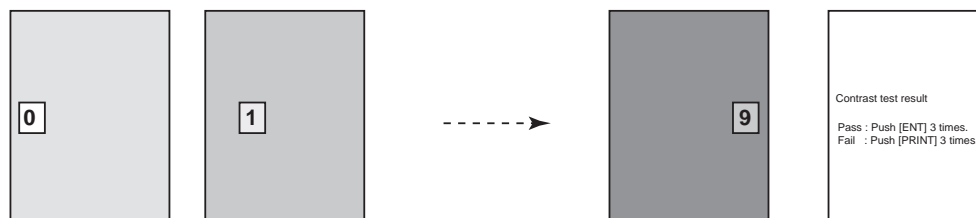
**Dimmer Test**

6. The dimmer level of the screen automatically changes in 10 levels as shown below. The screen displays the result of the Dimmer test last. If the test result is “Pass”, press the [ENT] key three times, and if the result is “Fail”, press the [PRINT] key three times and proceed to the next Internal Buzzer Test.

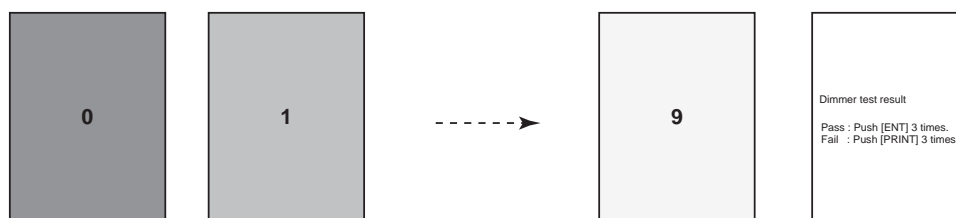
**Internal Buzzer Test**

7. Intermittent internal beeps (Key click beep) are outputted. If the test result is “Pass”, press the [ENT] key three times, and if the result is “Fail”, press the [PRINT] key three times and proceed to the next Alarm Buzzer Test.

<p><b>Internal Buzzer Test</b></p> <hr/> <p>Internal buzzer test result</p> <p>Pass Push [ENT] 3 times.</p> <p>Fail Push [PRINT] 3 times.</p>
-----------------------------------------------------------------------------------------------------------------------------------------------

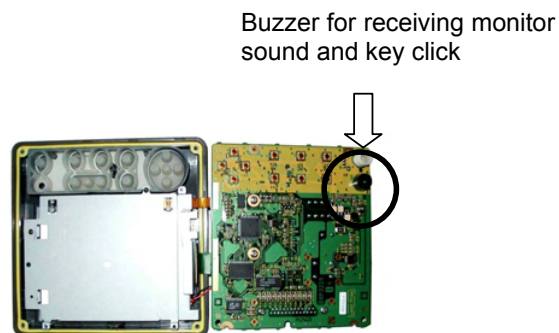

**Alarm Buzzer Test**

8. A continuous alarm beep is outputted in the test. If the test result is "Pass", press the [ENT] key three times, and if the result is "Fail", press the [PRINT] key three times and proceed to the next Contact Signal Test.

Alarm Buzzer Test
Alarm buzzer test result
Pass Push [ENT] 3 times. Fail Push [PRINT] 3 times.



Alarm beep generated when a message A, B, D or L is received.

**Contact Signal Test**

9. Check if the alarm output between #1 (ALM-H) and #2 (ALM-C) of J403 (WAGO) on NX-7001 is turned on and off at the every second. If the test result is "Pass", press the [ENT] key three times, and if the result is "Fail", press the [PRINT] key three times and proceed to the next Clock Test.

Contact Signal Test
Contact signal test result
Pass Push [ENT] 3 times. Fail Push [PRINT] 3 times.

**Clock Test**

10. This is a check for clock frequency of the CPU. If the clock frequency is not correctly set, receiving becomes impossible because synchronization with received signals cannot be maintained.

Check that the output frequency (5 V<sub>p-p</sub>) at U3-#2 (TEST SIGNAL) of the RCV board on NX-7001 is within 960 kHz  $\pm$  1.9 kHz.

If the test result is "Pass", press the [ENT] key three times, and if the result is "Fail", press the [PRINT] key three times and proceed to the next Output Test Result.

Clock Test
Clock test result
Pass Push [ENT] 3 times. Fail Push [PRINT] 3 times.

**Output Test Results**

11. If any key other than the power key is pressed, the results of the Factory Test are outputted to the printer.

Output Test Results

---

Connect PC.

Hit any key to send.

**Related information:**

The factory test results are displayed by selecting “System Test Results” in the Initialize1 menu.

<pre>CLOCK          : OK CONTACT SIGNAL : OK ALARM BUZZER   : OK INTERNAL BUZZER: OK DIMMER         : OK CONTRAST       : OK RECEIVER2      : NG RECEIVER1      : NG INS PORT       : OK PRINTER PORT   : NG KEY            : OK BATTERY        : OK EEPROM         : OK CPU RAM        : OK DRAM           : OK SRAM           : OK ROM            : OK --- TEST RESULT --- -?:\$!&amp;#()., '=/+ 0 1 2 3 4 5 6 7 8 9 abcdefghijklmnopqrstuvwxyz ABCDEFGHIJKLMNopqrstuvwxyz</pre>	<pre>CLOCK          : NG CONTACT SIGNAL : NG ALARM BUZZER   : NG INTERNAL BUZZER: NG DIMMER         : NG CONTRAST       : NG RECEIVER2      : NG RECEIVER1      : NG INS PORT       : NG PRINTER PORT   : NG KEY            : OK BATTERY        : OK EEPROM         : OK CPU RAM        : OK DRAM           : OK SRAM           : OK ROM            : OK --- TEST RESULT --- -?:\$!&amp;#()., '=/+ 0 1 2 3 4 5 6 7 8 9 abcdefghijklmnopqrstuvwxyz ABCDEFGHIJKLMNopqrstuvwxyz</pre>	<div style="border: 1px solid black; width: 40px; height: 40px; margin-bottom: 10px;"></div> <div style="border: 1px solid black; width: 40px; height: 40px; margin-bottom: 10px;"></div> <div style="border: 1px solid black; width: 40px; height: 40px;"></div>	<p>Prints the result of judgment of Pass or Fail by factory inspector.</p> <p>Prints the result of the Loopback test.</p> <p>Automatically prints the test result.</p>
------------------------------------------------------------------------------------------------------------------------------------------------------------------------------------------------------------------------------------------------------------------------------------------------------------------------------------------------------------------------------------------------------------------------------------------------------------------------------------	------------------------------------------------------------------------------------------------------------------------------------------------------------------------------------------------------------------------------------------------------------------------------------------------------------------------------------------------------------------------------------------------------------------------------------------------------------------------------------	-------------------------------------------------------------------------------------------------------------------------------------------------------------------------------------------------------------------------------------------------------------------	------------------------------------------------------------------------------------------------------------------------------------------------------------------------

← Printing test of printer

**Fig. 7.1.3 Example: Printing of Output Test Result**

**Turn off power**

12. Turn off the power if the screen shows the message “Turn off power”.

## 7.2 Rcv Monitor

This section describes information on monitoring of received signals.

To monitor a received signal on audio frequency,

Select “Int’l (518 kHz)” of “Local (490 kHz or 4209.5 kHz)” in “[MENU] -> System -> Signal Monitor”.

To output monitor sounds, internally created audio frequency is outputted if the received signal component has frequency component above 1700 Hz. If frequency is below 1700 Hz, audio frequency is not outputted.

### **Related information:**

To switch to local frequency, select “[MENU] -> NAVTEX -> Local Channel”.

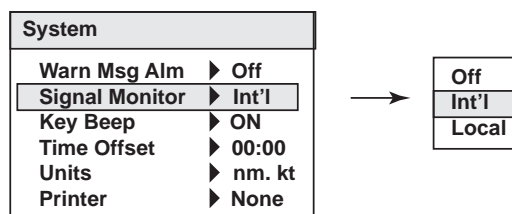

### 7.2.1 [MENU] -> Service -> Rcv monitor

A message being received can be displayed in real time to monitor the receiving condition. For instance, even when icons **L1** and **L1 (L2)** to show the “receiving” status are blinking, reception is stopped halfway, it may be caused due to the condition of radio-wave propagation, failure of the Receiver unit, noise jamming or etc.

A message is displayed as received.

### **Reference:**

The conditions for displaying (printing) a received message is;

- it is synchronized to the synchronizing signal broadcasted before ZCZC,
- ZCZC and message ID can be received correctly,
- the reception error rate is 33 % or less, and
- NNNN as the ending signal can be received.

Phasing signal >> 10s	ZCZC	One space	B1B2B3B4	CR + LF	Message	NNNN
--------------------------	------	--------------	----------	------------	---------	------

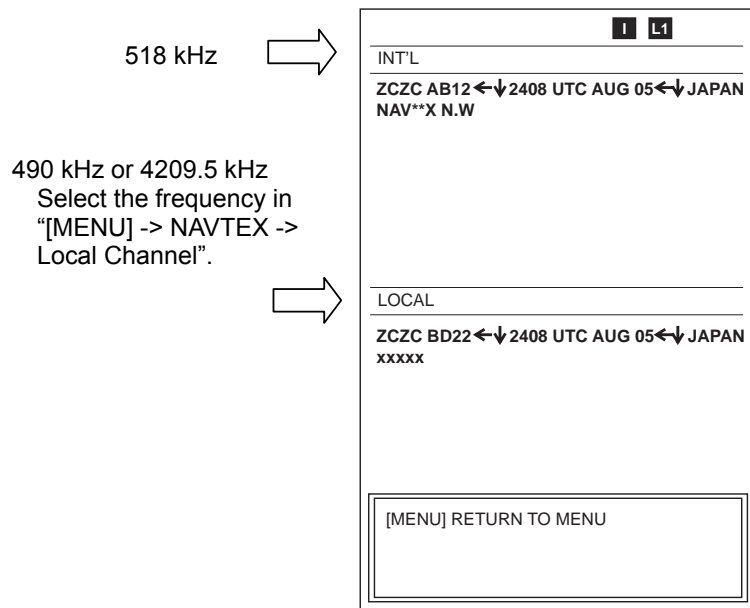

**I**, **L1**, **L2** blink.  
Blinks when synchronized to the  
synchronizing signal broadcasted  
before ZCZC.

- ←: CR (Carriage return)
- ↓: LF (line feed)
- \*: Error

## 7.3 Test in Initialize-1 and Initialize-2 menus

### 7.3.1 Test in Initialize-1 menu

#### 1. System Test Results

The System Test Results show the results of the factory test described in page 7-6. Normally, all the results are shown as “OK”. The test results are stored in U13 (EEPROM) and not cleared even if “All Clear” is executed in “[MENU] -> Initialize1 -> All Clear”.

#### 2. Initialize1 -> View Nav Data

This setting allows monitoring of IEC61162 sentences inputted between #4 (RD-A) and #5 (RD-B) of the INS port J402 (WAGO) on NX-7001.

**Note:**

Check that the baud rate (speed) of the inputted sentence meets the setting in “[MENU] -> Service -> INS Input Speed”. If the speeds do not match, the data cannot be read correctly. As a result,    is displayed.

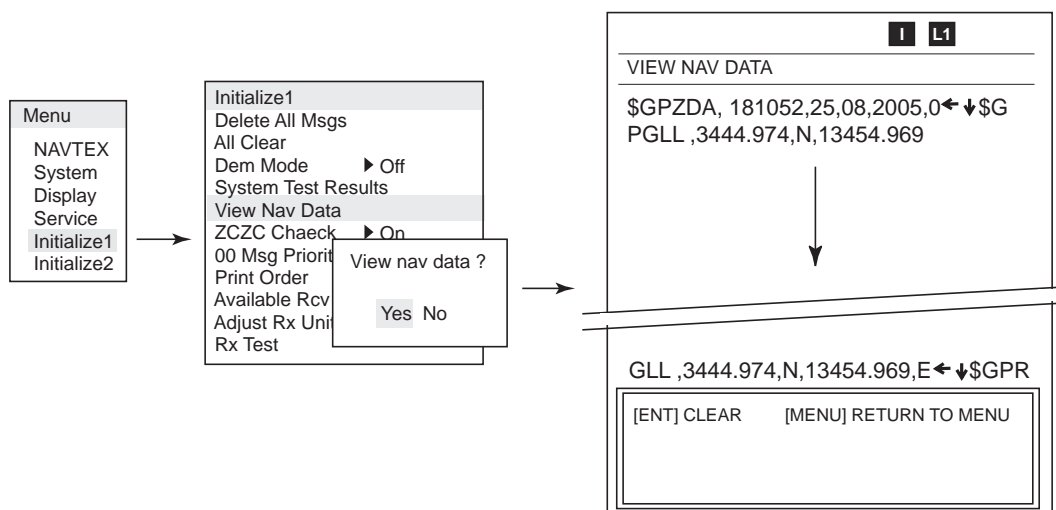

**Note;**

Every time the [ENT] key is pressed, the screen is updated.



### 3. Adjust Rx Unit

Dot signals of  $1700 \text{ Hz} \pm 85 \text{ Hz}$  and 100 bps are applied to the RCV board and adjustments are made on the receiving FSK detection circuit (U4, 5: NJN221). The section to be adjusted is VR shown below.

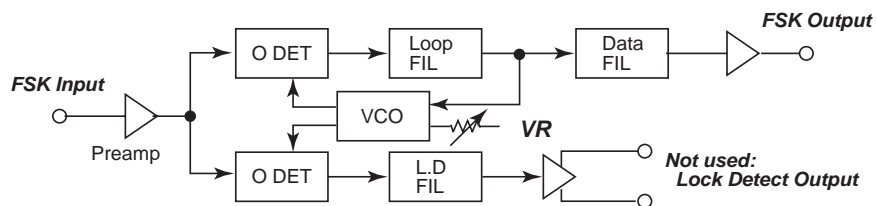

Fig. 7.3.1 NJN221 Block Diagram

#### Procedure

1. Execute "Rx Test" in [MENU] -> Initialize 1 menu.
2. In case of 518 kHz, adjust R60 so that the U4 output (U2-#3) has the duty ratio of  $50 \pm 5 \%$ .  
In case of 490 kHz or 4209.5 kHz, adjust R75 so that the U5 output (U3-#3) has the duty ratio of  $50 \pm 5 \%$ .

#### Note:

When the duty ratio of B and Y signals differ, the received signal cannot be decoded correctly. The tracking width of the received frequency becomes smaller than for approximately  $(1700 \text{ Hz} \pm 85 \text{ Hz}) \pm 40 \text{ Hz}$ .

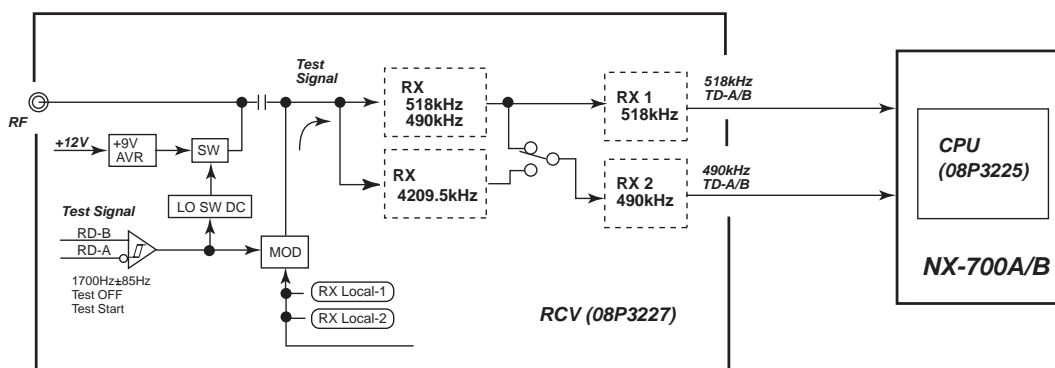

Fig. 7.3.2 Adjustments of receiving circuit

### 4. Rx Test

This test is the same as the receiving test in the setting of "[MENU] -> Service -> Test". See page 7-3 for details.

## 7.3.2 Tests in Initialize-2 menu

### 1. Serviceman Test

See page 7-5 for details.

### 2. Fill Memory

This test is used for the Type approval test.

When “Fill Memory” is executed, the memory area of messages is 100 % filled.

Do not carry out this test on board. All the received messages are deleted.

If this test is performed, currently stored received messages are all deleted and 200 test messages including 500 characters are stored for 518 kHz and currently selected local frequency (490 kHz or 4209.5 kHz), respectively.

After completing this test, clear test messages by executing “[MENU] -> Initialize1 -> Delete All Msgs”.

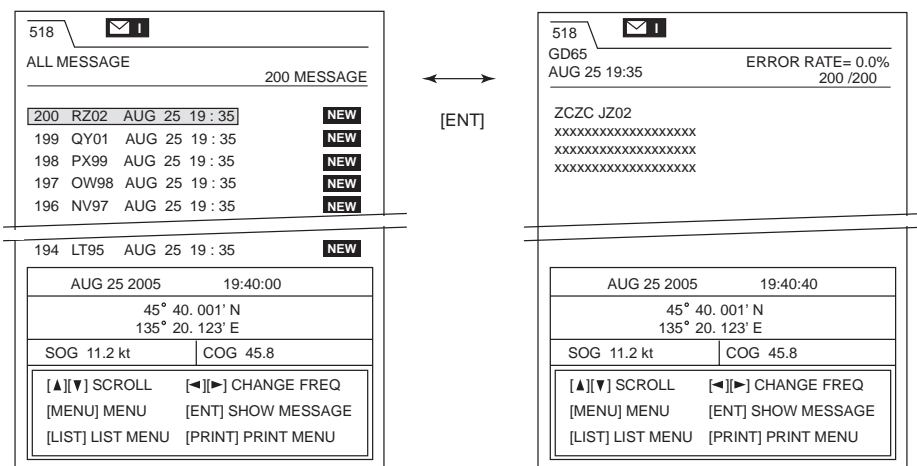

### 3. Rcv Mon + NMEA Test

This test is used for the Type approval test.

Rcv Mon and NMEA Loopback Test are performed. “Rcv Mon” is the same test as described in page 7-10.

In the NMEA Test, NMEA data inputted from #4 (RD-A) and #5 (RD-B) terminals of J402 (WAGO) of the INS port on NX-7001 are outputted to #1 (TD-A) and #2 (TD-B) terminals of J402 as they are.

## 7.4 Memory Clear

This section describes information on clearing memory.

### 1. [MENU] -> Service -> Default Setting

This setting restores the user setting menu to the default, except “Edit Station List” in “[MENU] -> Service” menu. However, received messages are not deleted.

Select “[MENU] -> Service -> Default Setting”. Select “Yes” and then press the [ENT] key.

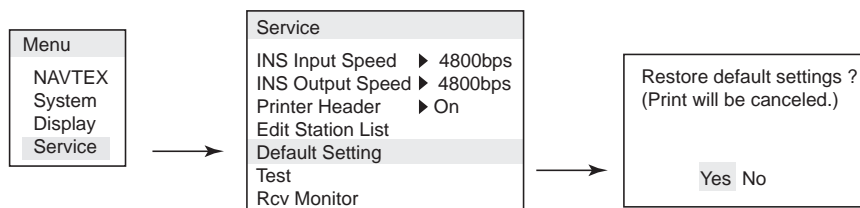

### 2. [MENU] -> Initialize 1 -> All Clear

All the settings are reset to the default and received messages are deleted.

Select [MENU] -> Initialize 1 -> All Clear. Select “Yes” and then press the [ENT] key.

When “All Clear” is executed, select “On” in the setting of “[MENU] -> Initialize2 -> Russia Mode” for the Russian type equipment.

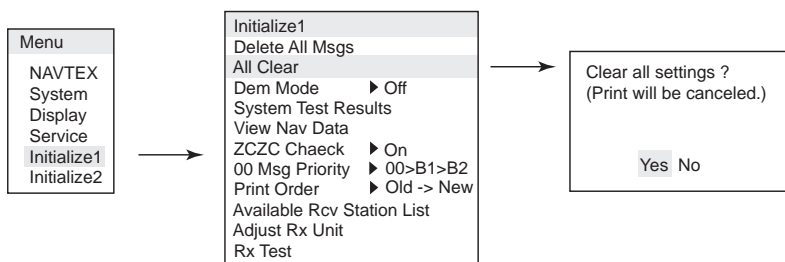

### 3. [MENU] -> Initialize 1 -> Delete All Msgs

All received messages are cleared.

Select Initialize 1 -> Delete All Msgs. Select “Yes” and then press the [ENT] key.

**4. Items to be cleared**

Items that can be cleared in operations 1, 2 and 3 described previous page are as follows.

<b>Items to be cleared</b>	<b>Default Setting operation</b>	<b>All Clear operation</b>	<b>Delete All Msgs operation</b>
[Menu] -> NAVTEX	Yes	Yes	No
[Menu] -> Display	Yes	Yes	No
[Menu] -> System	Yes	Yes	No
[Menu] -> Service	Yes (Except "Edit Station List")	Yes	No
[Menu] -> Initialize 1	No	Yes	No
[Menu] -> Initialize 2	No	Yes	No
Received message	No	Yes	Yes

## 7.5 Popup Message

When a certain event occurs, a user is notified of it on the popup message display.

Table 7.5.1 Popup message list of handling of Received message

Popup of handling of received message	Description
Received new local msg. Display new msg ? Yes/No	This popup message is displayed when a new message is received on the local frequency (490 kHz or 4209.5 kHz). <b>Related information:</b> Switching of frequency [MENU] -> NAVTEX -> Local Channel
Received new int'l msg. Display new msg ? Yes/No	This popup message is displayed when a new message is received on the international frequency (518 kHz).
New message received. Oldest message deleted to free up memory.	This popup message is displayed when a new message is received while the oldest received message is displayed with the memory for received messages filled and the oldest received message is deleted. The memory capacity for received messages is up to 200 messages for the international frequency and local frequency, respectively. Assuming the average number of characters of one message to be 500 characters, the number of characters to be stored is $200 \times 500 = 100,000$ for each frequency.
Same message with lower error rate received. Currently displayed message will be deleted.	This popup message is displayed when a message having the same ID as an already stored received message is received again, the newly received message has a lower error rate than the previously received message, and the received message is displayed. The displayed received message is replaced with the new message. A received message with the error rate between 4 % and 33 % (inclusive) can be stored.
Term of validity expired. Currently displayed message will be deleted.	Shows the term of validity of a received message. This popup message is displayed when 66 hours have elapsed after a message was received and before the message is deleted. A received message which is protected by selecting "Lock Message" on the [LIST] menu while the received message list is displayed is not deleted.
Message not chosen for display received; it is a int'l 00 message. Choose "All Message"(LIST menu) to display.	In reception on the international frequency; 1. When "Alarm Message (A/B/D/L)" is selected on the [LIST] menu and an emergency message (ID = xx00) other than alarm messages is received. 2. When "Non-display" is selected for the station or received message in "[MENU] -> Display -> User Select Station & Msg" and "User Select Message" is selected on the [LIST] menu and an emergency message (ID = xx00) is received. 3. When "Good Message" is selected on the [LIST] menu and when an emergency message (ID = xx00) with the error rate of 4 % to 33 % is received. <b>Note:</b> To display the received message, select "All Message" on the [LIST] menu.

<p>Message not chosen for display received; it is a local 00 message. Choose "All Message"(LIST menu) to display.</p>	<p>In reception on the local frequency;</p> <ol style="list-style-type: none"> <li>1. When "Alarm Message (A/B/D/L)" is selected on the [LIST] menu and an emergency message (ID = xx00) other than an alarm message is received.</li> <li>2. When "Nondisplay" is selected for the station or received message in "[MENU] -&gt; Display -&gt; User Select Station &amp; Msg" and "User Select Message" is selected on the [LIST] menu and when an emergency message (ID = xx00) is received.</li> <li>3. When "Good Message" is selected on the [LIST] menu and an emergency message (ID = xx00) with the error rate of 4 % to 33 % is received.</li> </ol> <p><b>Note:</b> To display the received message, select "All Message" on the [LIST] menu.</p>
<p>Int'l message not chosen for display received. Choose "All Message" (LIST menu) to display.</p>	<p>In reception on the international frequency; When a message selected in the setting of "[MENU] -&gt; NAVTEX -&gt; Rcv Mask" is received.</p> <ol style="list-style-type: none"> <li>1. When a message other than an alarm message is received when "Alarm Message" is selected on the [LIST] menu.</li> <li>2. When "User Select Message" is selected on the [LIST] menu and a message is received for which "Nondisplay" is selected on the station or received message in "[MENU] -&gt; Display -&gt; User Select Station &amp; Msg".</li> <li>3. When "Good Message" is selected on the [LIST] menu and a message with the error rate of 4% to 33% is received.</li> </ol> <p><b>Note:</b> To display the received message, select "All Message" on the [LIST] menu.</p>
<p>Local message not chosen for display received. Choose "All Message" (LIST menu) to display.</p>	<p>In reception on the local frequency; When a message selected in the setting of "[MENU] -&gt; NAVTEX -&gt; Rcv Mask" is received.</p> <ol style="list-style-type: none"> <li>1. When a message other than an alarm message is received when "Alarm Message" is selected on the [LIST] menu.</li> <li>2. When "User Select Message" is selected on the [LIST] menu and a message is received for which "Nondisplay" is selected on the station or received message in "[MENU] -&gt; Display -&gt; User Select Station &amp; Msg".</li> <li>3. When "Good Message" is selected on the [LIST] menu and a message with the error rate of 4% to 33% is received.</li> </ol> <p><b>Note:</b> To display the received message, select "All Message" on the [LIST] menu.</p>

Table 7.5.2 Printer and Battery error popup list

Printer & battery error popup	Description
Printer error	Printer error Displayed when paper runs out or the printer door is open. Related setting; Printer setting [MENU] -> System -> Printer
Battery error	Displayed when the voltage of the backup battery of the CPU board goes down below +2.5 VDC. The Status field of the received message shows <input type="checkbox"/> <input checked="" type="checkbox"/> mark. To check the battery voltage, execute “[MENU] -> Service -> Test”.

Table 7.5.3 Popup list for each menu

Popup list for each menu	Applicable menu
Restore default settings ?	[MENU] -> Service -> Default Setting
Start test ?	[MENU] -> Service -> Test
Delete all message ?	[MENU] -> Initialize1 -> Delete All Msgs
Clear all settings ?	[MENU] -> Initialize1 -> All Clear
View nav data ?	[MENU] -> Initialize1 -> View Nav Data
Display system test results ?	[MENU] -> Initialize1 -> System Test Results
Adjust Rx unit ?	[MENU] -> Initialize1 -> Adjust Rx Unit
Start Rx test ?	[MENU] -> Initialize1 -> Rx Test
Start serviceman test ?	[MENU] -> Initialize2 -> Serviceman Test
Fill Rx memory with test message ?	[MENU] -> Initialize2 -> Fill Memory

**Note:**

When “NX-700A, Upright, or Inverted” is selected in the setting of “[MENU] -> System -> Printer”, a message “Print will be canceled” is added.

Table 7.5.4 Edit station list menu popup list

Popup Message in Edit Station List menu	Applicable menu
Delete Station ?	[MENU] -> Service -> Edit Station List
Save new station ?	[MENU] -> Service -> Edit Station List
Save new station ?	[MENU] -> Service -> Edit Station List
Edit ID data.	[MENU] -> Service -> Edit Station List
Exit without saving ?	[MENU] -> Service -> Edit Station List
Save station ?	[MENU] -> Service -> Edit Station List

## 7.6 Replacement of Battery

Replace the battery of the CPU board when  is displayed in the Status display field. When the battery is replaced, all the backed-up received messages are cleared. But the user-programmed menu settings are not cleared.

### Reference:

1. Execute “[MENU] -> Service -> Test”.  
In the Memory Test, battery voltage can be checked.

Item	Value for reference
Interval for battery replacement	5 to 10 years
When newly installed	+3.3 VDC
 display voltage	2.5 VDC or less
Minimum voltage for backup	1.8 VDC or more
Time for voltage drop from +2.5 VDC to +1.8 VDC	1,000 hours at the shortest

2. Received messages and each setting are stored in the SRAM of the CPU board and backed up by the battery. The EEPROM compares settings of the SRAM every hour and update changes, if any, to back up data of the SRAM.

For instance, if the battery is replaced immediately after a setting is changed, the changed setting has not been stored in the EEPROM yet and previous setting data is sent to the SRAM. As a result, it follows that “setting has not been changed”.



1. Disconnect the plug J7 and replace the battery. The battery is secured with silicone rubber. Remove the battery exercising caution so as not to damage other parts.
2. When a new battery is installed, secure the battery with silicone rubber as the old battery was.
3. Connect the plug J7.

Fig. 7.5.1 Replacement of Battery on CPU board



## 7.7 Troubleshooting

### 1. The power is not turned on.

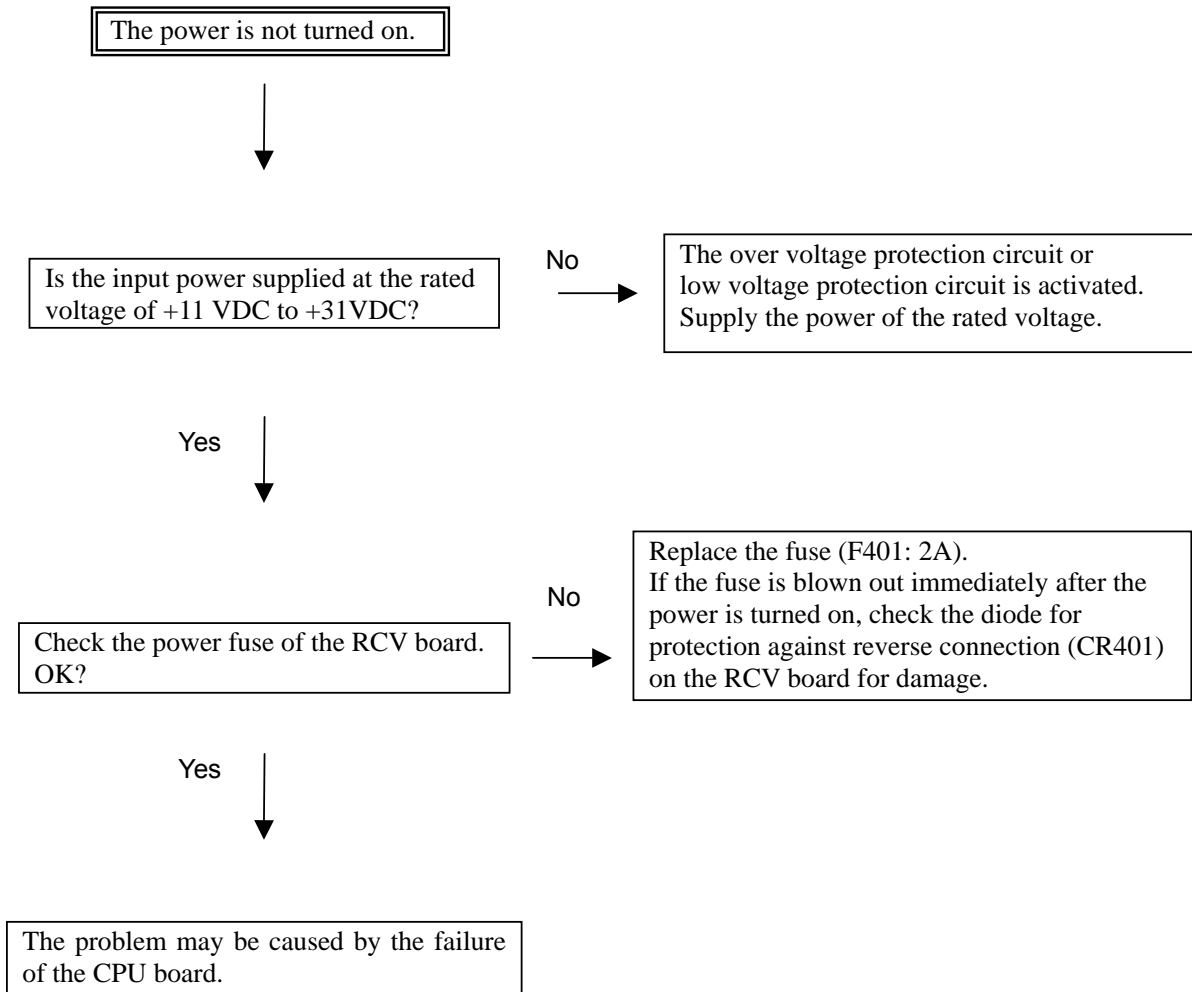

## 2. Reception trouble-1) No reception

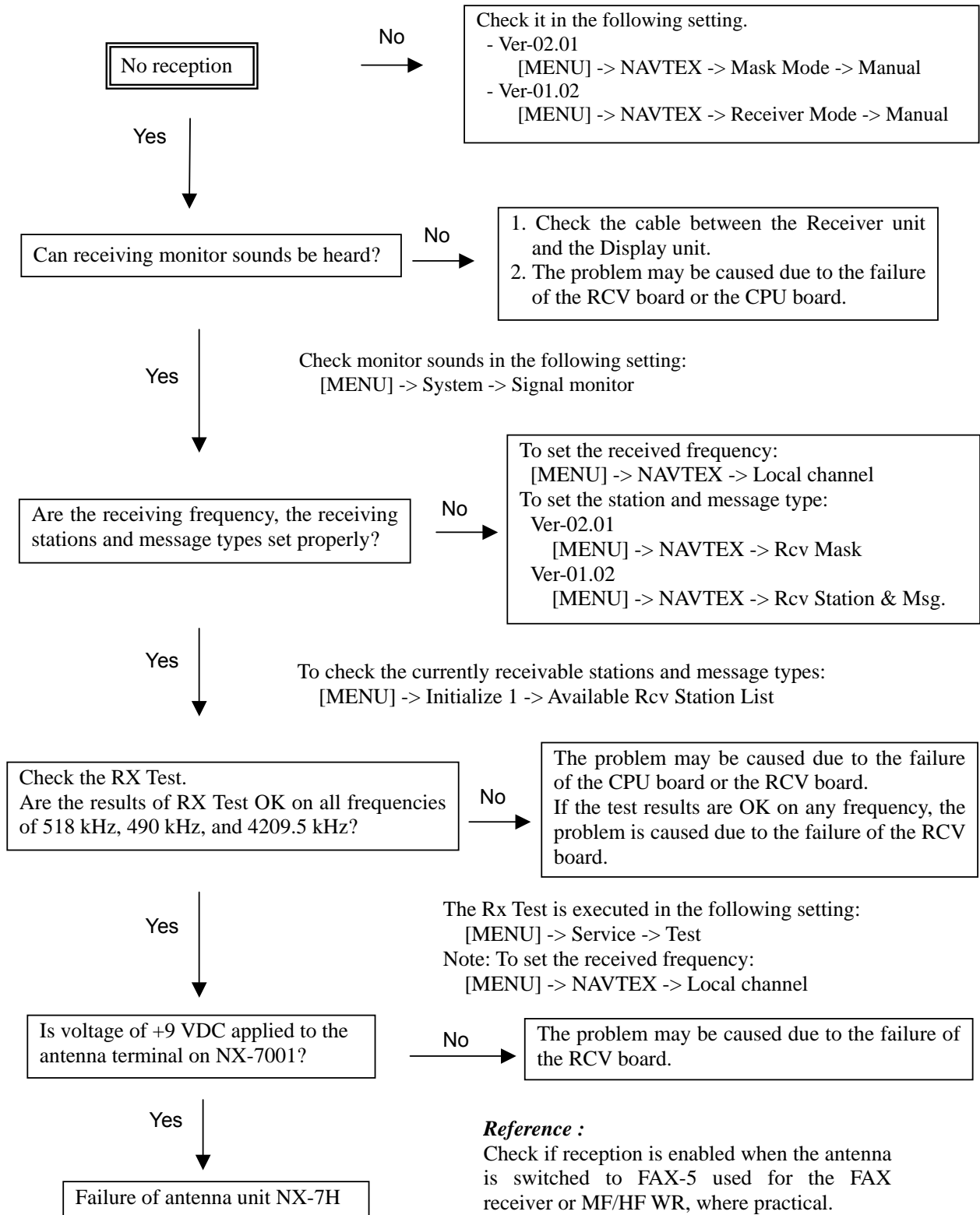

### 3. Reception trouble-2) There are many reception errors.

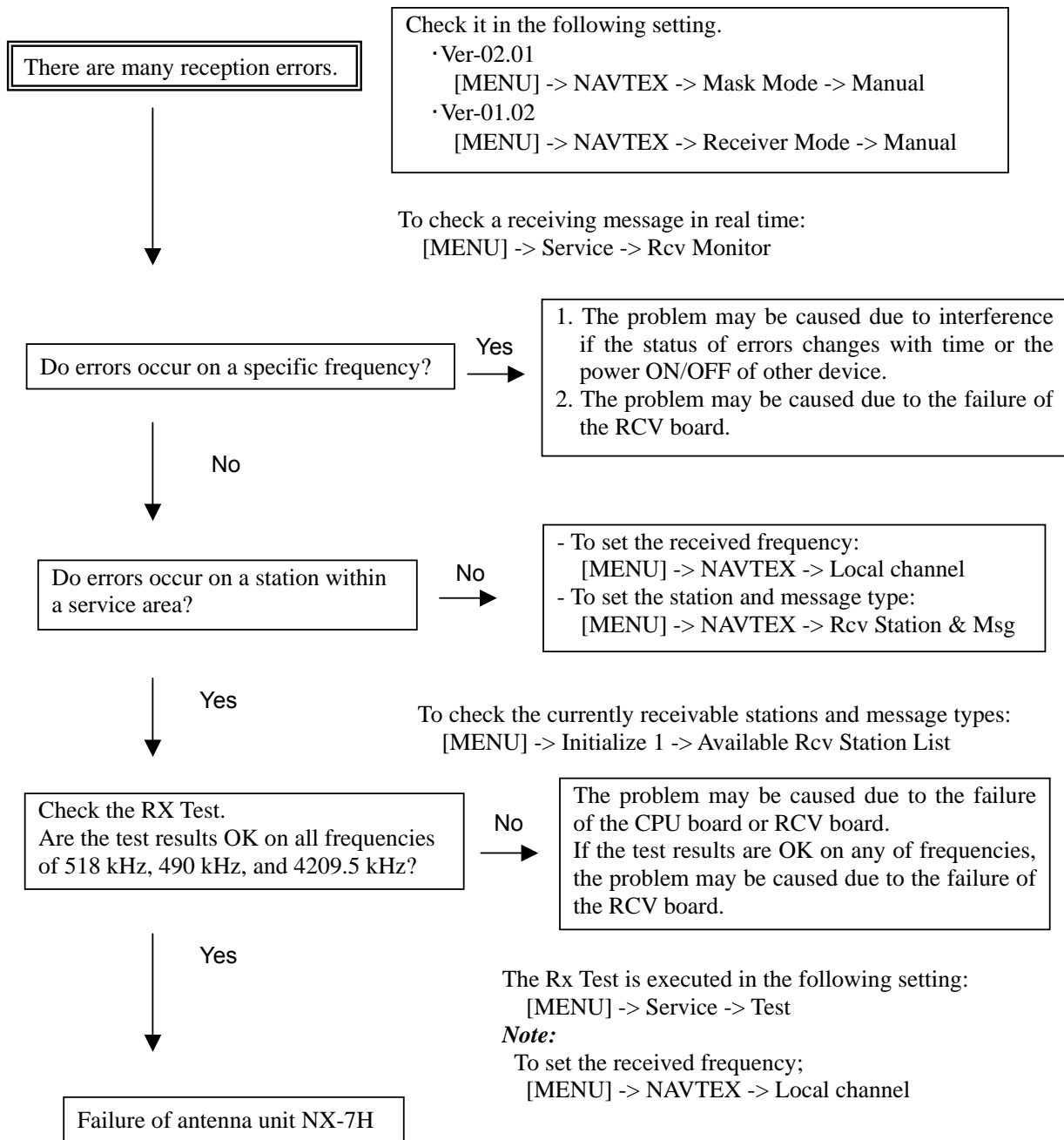

**Reference:**

1. Check if reception is enabled when the antenna is switched to FAX-5 used for the FAX receiver or MF/HF WR, where practical.
2. Reception is stopped when the rate of receiving errors exceeds 33%.

#### 4. NMEA data is not inputted from the GPS.

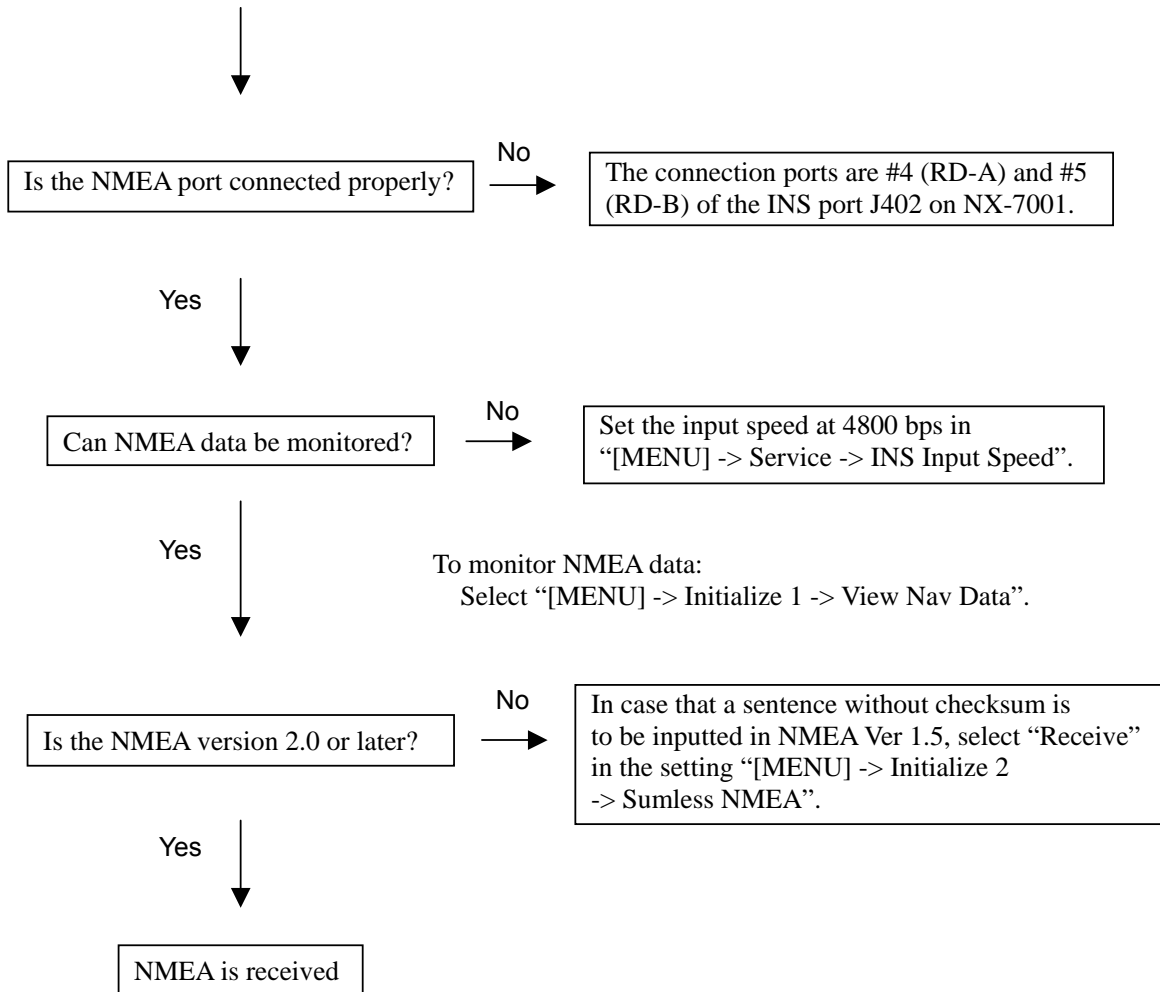
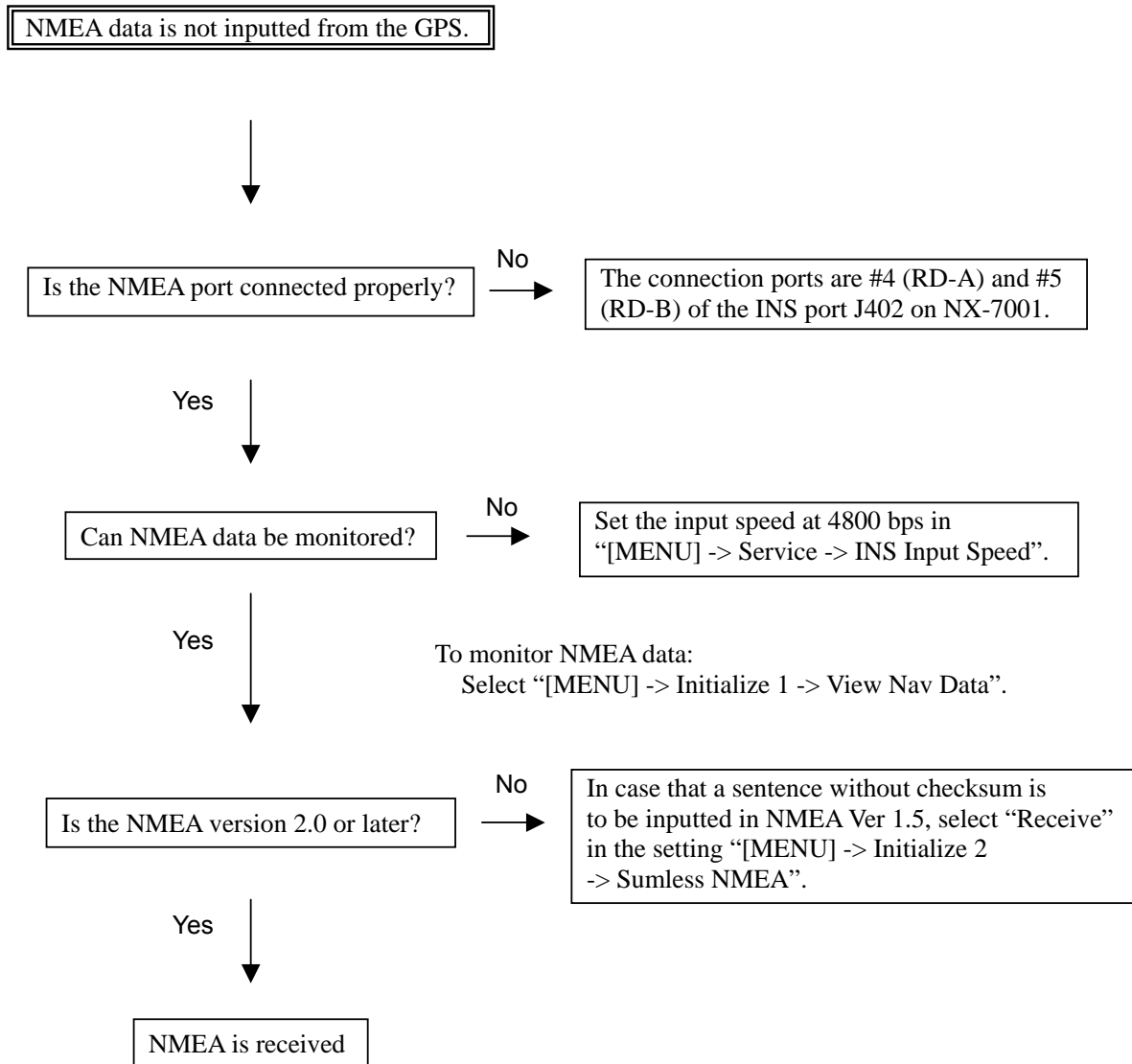

#### Reference :

1. Sentences that can be received are as follows
  - Time, Date      ZDA
  - Position        GNS > GGA > RMC > GLL
  - SOG             VTG > VBW > RMC
  - STW            VHW > VBW
  - COG            VTG > RMC
2. Without the entry of the ZDA sentence, the time stamp on the header of printing and the reception time to be displayed in the reception list are shown blank.
3. Without the entry of the position data, the Auto mode does not work.

**5. The printer does not operate.**

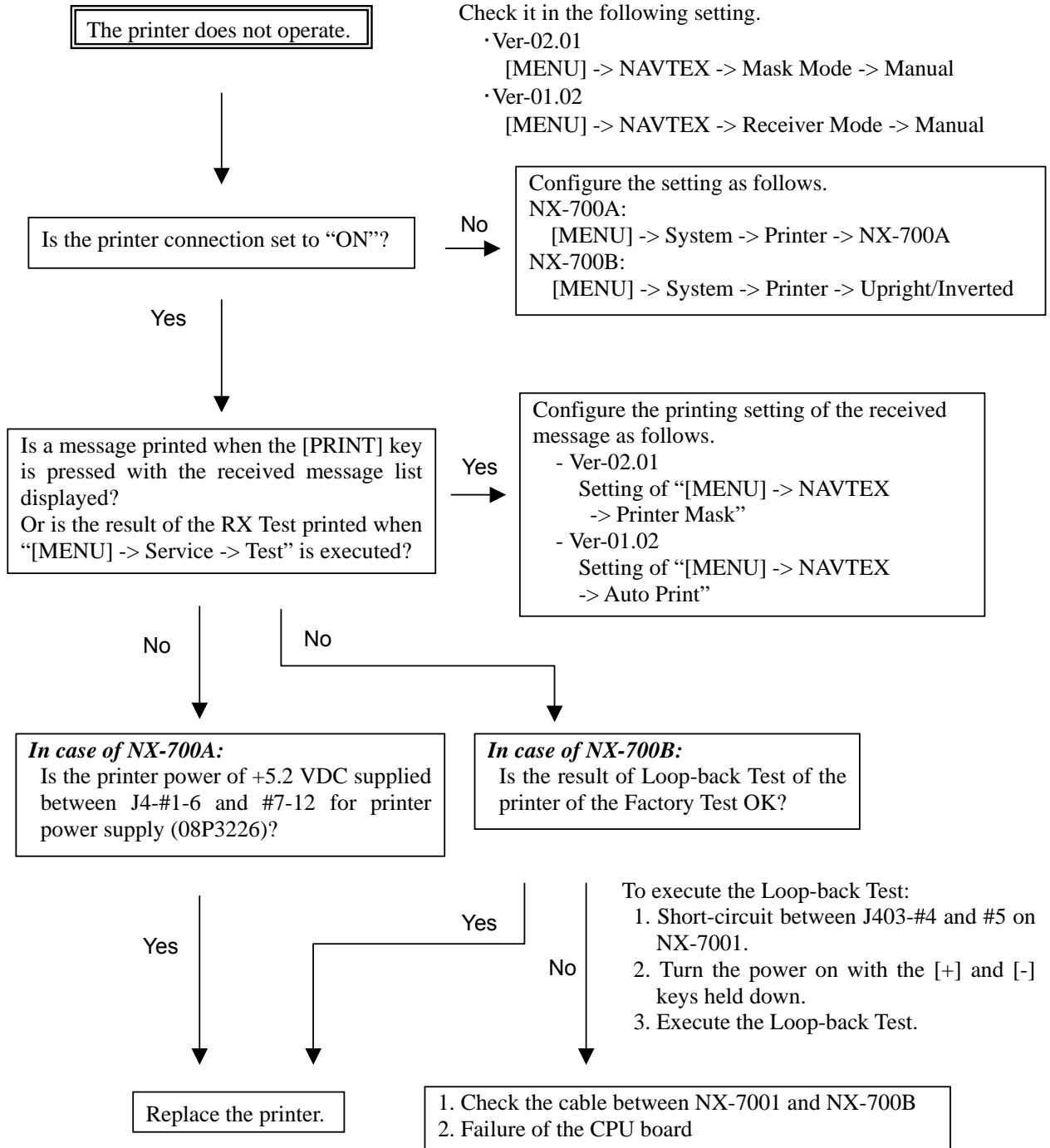

## Chapter 8. Q & A

- Q1. Can the FAX-5 antenna unit be used with NX-700A and B?  
It can be used in terms of electric characteristics. However, since the requirements for the Type approval of NX-700A and B include the Antenna unit NX-7H, the FAX-5 antenna cannot be used with NX-700A and B.
- Q2. Can the NX-5 antenna unit be used with NX-700A and B?  
No.  
Since the requirements for the Type approval of NX-700A and B include the Antenna unit NX-7H, the NX-5 antenna cannot be used with NX-700A and B.  
NX-5 is an Antenna unit dedicated for reception on 518 kHz. If the Antenna unit of NX-5 is used, the receiver sensitivity is reduced particularly on local frequency 4209.5 kHz.
- Q3. Give information on the specifications of a connectable printer. (5-13)  
Serial printer: 9600 bps, 8 bit data, non parity, 1 bit stop-bit, Xon/Xoff, 32 Char/line
- Q4. What part should the Nav data (GPS) be connected to? (2-5)  
Connect the Nav data to #4(RD-A) and #5(RD-B) of J402 on NX-7001. Be sure to make a connection to #3 (ISO GND).
- Q5. What is the length of the cable between the Display unit and the Receiver unit? (1-2)  
Communication between Display unit and Receiver units is achieved via RS-232C. Since this cable includes the power supply line, the cable length differs according to the specifications of the power supply. It is 3 m for +12 VDC power supply and 15 m for +24 VDC power supply.
- Q6. When the NX-700A/B is used at an exhibition or presentation, is it needed to connect the Antenna unit? (2-25)  
It is NOT necessary. Operate it in the DEMO mode. To enter this mode, select ON in “[MENU] -> Initialize1 -> Demo Mode”.
- Q7. Is there any difference according to the input power (+12/24 VDC)? (3-9)  
There is NO difference by the input power.  
There is no need to change the fuse (2 A) on the RCV board of NX-7001. This fuse is intended for protection against reverse connection.
- Q8. The INS connection port is of the RS-485 type. How is the ON/OFF setting of the terminating resistor performed? (3-6)  
The setting is performed at J9 on the CPU board of the Display unit. The plug J9 is inserted between #1 and #2, it is set as “With termination”. (Default setting)  
Do not connect the INS I/O port to be connected to NX-700A and B in parallel with other equipment and use it on its own. In this case, leave the setting of J9 at default as “With termination”.

- Q9. Under what conditions is an alarm outputted? (2-16)  
 An alarm is outputted when a message D, A, B or L is received. However, a message A, B and L can be set as ON or OFF by the setting of “[MENU] -> System -> Warn Msg Alm”.
- Q10. How can the alarm output be checked? (7-8)  
 It would be better to check the alarm action waiting for the receipt of an alarm message. However, this method does not allow checking on alarm output on the instant. It can be checked in “Contact Signal Test” in the Factory Test menu. To enter the Factory Test menu, turn the power on while holding down the [+] and [-] keys of the DIM. The alarm output is normally open with MOS relay output. The alarm output and alarm buzzer are linked with each other.
- Q11. Should only pressing any key stop an alarm? (2-28)  
 An alarm can also be stopped by the ACK sentence from the INS. The setting for this;
- In case of program Ver-01.02:  
 Select “INS” in “[MENU] -> NAVTEX -> Receive Mode”  
 Select “Receive” in “[MENU] -> Initialize2 -> ACK Command”
  - In case of program Ver-02.01:  
 Select “INS” in “[MENU] -> NAVTEX -> Mask Mode”  
 Select “Receive” in “[MENU] -> Initialize2 -> ACK Command”
- Q12. Power cannot be turned on. What parts should be checked? (3-9, 5-11)  
 The power is inputted through NX-7001, from which power is supplied to the Display unit.
- 1) Check the fuse (2 A) on the RCV board of NX-7001.
  - 2) The operating range of the power supply voltage input is between +10.8 VDC and +31.2 VDC.
- The power supply block is incorporated in the CPU board of the Display unit.
- Q13. Nav data is not displayed. What parts should be checked? (2-6)  
 Check the following points.
- 1) Check the input sentence. The acceptable sentences are ZDA, GNS, GGA, RMC, GLL, VTG, VBW and VHW.
  - 2) Is the sentence inputted to NX-700A and NX-700B added with a checksum? Sentences with a checksum are those of NMEA Ver-2.0 or later, or IEC61162. In case that a sentence without a checksum needs to be inputted, select “Receive” in “[MENU] -> Initialize2 -> Sumless NMEA.”
  - 3) Check the bit rate of the serial data input of the Nav data. It can be checked in “[MENU] -> Service -> INS Input Speed.” The bit rate should be 4800 when directly connected to the GPS. When connection is made via the INS, set the input speed according to the communication speed with the INS.
  - 4) The serial data input can be checked in “[MENU] -> Initialize1 -> View NAV Data”.

- Q14. The received time does not display in the receiving list. (1-3)  
ZDA sentence is not inputted. Input the ZDA sentence.
- Q15. What does the "Distance" showed on the user display represent? (1-10, 2-21)  
It is the distance between the own ship position and the position information of a ship nearest to the own ship included in the received message. This is the distance information for a user to find whether the message is relevant to the own ship. This is not the distance between the received station and the own ship.
- Q16. Messages cannot be received even in receiving time. (5-6, 7-3)  
It may be caused due to a failure of the Antenna unit or Receiver unit.
- 1) Check that power +9 VDC for power supply to the Antenna unit is applied to the antenna connector. If the power is not applied, the problem is a failure of the RCV board.
  - 2) Execute "[MENU] -> Service -> Test." If the result of Rx Test is OK, it is caused due to a failure of the Antenna unit.
  - 3) To know which is faulty, Receiver unit or Antenna unit, replace the Antenna unit used for a FAX receiver device or MF/HF WR with an FAX-5 antenna unit. If it becomes possible to receive messages by this, the problem lies with the Antenna unit.
- Q17. Although the icon showing the "During receiving" on 518 kHz is displayed, a message cannot be received. (5-6, 7-13)  
If a message can be received on 490 kHz or 4209.5 kHz, it is caused by a failure of the RCV board. The receiving circuit of the RCV board is comprised of two circuit systems of 518 kHz and 490 kHz/4209.5 kHz.  
Judging from the symptom, it is probably caused by pulling out of synchronism due to incorrect adjustments of FSK detection on 518 kHz.
- Q18. Although the received signal intensity seems to be strong enough, a message cannot be received. (7-10)  
It is probably caused by the same reason as described in Q17. Even if the signal intensity is strong enough, if synchronization is not achieved properly, reception is stopped when the error rate exceeds 33 %. The signal receiving status can be monitored by the setting of "[MENU] -> Service -> Rcv Monitor".
- Q19. A received message cannot be printed. (2-19)  
Check the setting of "[MENU] -> System -> Printer." Select "NX-700A" for the type NX-700A. In case of type NX-700B, configure the setting according to the specification of the printer.
- Q20. The icon  showing "during printing" is displayed in the Status field of NX-700B (not incorporating a printer). (2-19)  
Execute "Cancel" of the printer on the [PRINT] menu.  
Then, select OFF in "[MENU] -> System -> Printer."



Q21. A new station starts operation. Is it needed to change the program or circuit to receive messages from this station? (2-24)

Stations can be edited by addition, deletion and change, etc. in the setting of “[MENU] -> Service -> Edit Station List.”

In addition, Auto mode is performed on the basis of this data.

Q22. How can the program number be checked? (7-5)

It is not possible to check the detailed version of the program in “Memory Test” of “[MENU] ->Service -> Test.” Check the detailed version of the program in “Memory Test” of “[MENU] -> Initialize2 -> Serviceman Test.”

Q23. A program cannot be updated. (Chapter 6)

- 1) To update a program, use the [RECEIVER] port of the LCD display. Please note this is not the [RECEIVER] port on the casing of the Display unit on NX-700A.
- 2) A batch file can be specified via COM 1. When the serial port number of the PC is specified as other than COM-1, change the setting of the serial port number to “COM-1” on the PC, or change the setting of the COM port number of the batch file.

Q24. The icon showing “Battery drain” is displayed.

What problems should occur? (7-20)

This icon is displayed when the lithium battery voltage of the CPU board on the Display unit is drained below +2.5 VDC.

When the battery voltage further goes down below +1.8 VDC, it becomes impossible to back up the memory of received messages. Time for the battery voltage going down from +2.5 VDC to +1.8 VDC is 1,000 hours at the shortest.

Replace the battery within about one month after this icon is displayed first.

Q25. What is the important information of the Operator’s Manual? (Chapter 1)

The most important information is the configuration and meaning of IDs (station, message type, “00” message), status display icons on the received message display screen, selection of local frequency and installation position of the Antenna unit.

For selection of stations, it is necessary to understand the Auto mode. The received message type is set “Select All” at default. This setting should be changed depending on the situation.

# Appendix 1. Specifications

---

## 1. NAVTEX RECEIVER

- |     |                     |                                                                                                                                                                                                                                                                                                                                                                                                                                                                      |
|-----|---------------------|----------------------------------------------------------------------------------------------------------------------------------------------------------------------------------------------------------------------------------------------------------------------------------------------------------------------------------------------------------------------------------------------------------------------------------------------------------------------|
| 1.1 | Receiving frequency | 518 kHz and 490 kHz (or 4209.5 kHz),<br>receive both frequencies simultaneously                                                                                                                                                                                                                                                                                                                                                                                      |
| 1.2 | Mode of reception   | F1B                                                                                                                                                                                                                                                                                                                                                                                                                                                                  |
| 1.3 | Sensitivity         | 2 $\mu$ V e.m.f. (50 ohms), 4 % error rate or less                                                                                                                                                                                                                                                                                                                                                                                                                   |
| 1.4 | Input protection    | Withstands 30 Vrms for 15 minutes or more (w/ pre-amp unit)                                                                                                                                                                                                                                                                                                                                                                                                          |
| 1.5 | Spurious emission   | 1 nW or less                                                                                                                                                                                                                                                                                                                                                                                                                                                         |
| 1.6 | Message category    | A: Navigation warning<br>B: Meteorological warning<br>C: Ice report<br>D: Search and rescue information/ pirate attack warnings<br>E: Meteorological forecast<br>F: Pilot message<br>G: AIS<br>H: Loran message<br>I: Spare<br>J: SATNAV messages<br>K: Other electronic navigational aid and system message<br>L: Navigational warning (addition to "A")<br>V to Y: Special services allocation by the NAVTEX<br>Co-ordinating Panel<br>Z: QRU (no message on hand) |

## 2. DISPLAY UNIT

- |     |                 |                                                                |
|-----|-----------------|----------------------------------------------------------------|
| 2.1 | Display system  | 5-inch, 76 (W) x 100 (H) mm, monochrome LCD,<br>240 x 320 dots |
| 2.2 | Display modes   | Message selection mode, Message display mode                   |
| 2.3 | Message storage | 200 messages x 2 channels<br>(100,000 characters x 2 channels) |

### **3. PRINTER SECTION**

3.1	Printing system	Line thermal head printing system
3.2	Printing paper	Thermal paper (58 mm x 30 m)
3.3	Printing width	48 mm
3.4	Character format	24 x 12 dot
3.5	Dot pitch	8 dots/ mm
3.6	Number of characters	32 characters/line
3.7	Print speed	Approx. 20 mm/sec.

### **4. ANTENNA UNIT**

4.1	Antenna type	NX-7H: H-field antenna
4.2	Output impedance	50 ohms
4.3	Power supply	+7 VDC to +9 VDC (thru coax. cable)

### **5. INTERFACE**

5.1	Input data	IEC61162-1/2 GGA, GLL, RMC, ZDA, NRQ, NMK, ACK, GNS, VHW, VTG, VBW
5.2	Output data	NRX, ALR
5.3	Alarm	Photo MOS Contact closure signal (max. 0.5 A, 50 V) for SAR alert

### **6. POWER SUPPLY**

+12 VDC to +24 VDC: 1.5 A to 0.8 A

### **7. ENVIRONMENTAL CONDITION**

7.1	Ambient temperature	
	Antenna unit	-25°C to +70°C
	Receiver / Display unit	-15°C to +55°C
7.2	Relative humidity	95 % at 40°C (without dew condensation)

7.3 Waterproofing

- Antenna unit IP66
- Receiver / Display unit IP20

- 7.4 Vibration 2 Hz to 5 Hz and up to 13.2 Hz with a deviation of  $\pm 1$  mm  $\pm 10$  %  
(7 m/s<sup>2</sup> maximum acceleration at 13.2 Hz);  
above 13.2 Hz and up to 100 Hz with a constant maximum  
acceleration of 7 m/s<sup>2</sup>

**8. COATING COLOR**

- 8.1 Display unit N3.0
- 8.2 Receiver unit N3.0
- 8.3 Antenna unit N9.5





# Contents of Drawings

Name		Type	Dwg. No.	Page
NX-700A/B Interconnection Diagram		—	C5649-C01	S-1
Display unit	NX-700A	—	C5649-K01	S-2
Display unit	NX-700B	—	C5649-K02	S-3
RCV board	NX-7001	—	C5649-K04	S-4
	RCV	08P3227-1/2	C5649-K05	S-5
	RX1, RX2	08P3227-2/2	C5649-K06	S-6
CPU board	CPU	08P3225-1/4	C5649-K07	S-7
		08P3225-2/4	C5649-K08	S-8
		08P3225-3/4	C5649-K09	S-9
		08P3225-4/4	C5649-K10	S-10
PWR board	PWR	08P3226-1/2	C5649-K11	S-11
		08P3226-2/2	C5649-K12	S-12
Antenna unit	NX-7H	08P3228A/B	C5649-K03	S-13
AC/DC Power supply	PR-240CE	—	C5003-K02	S-14
	PLE	PLE24HSZ	C5003-K03	S-15

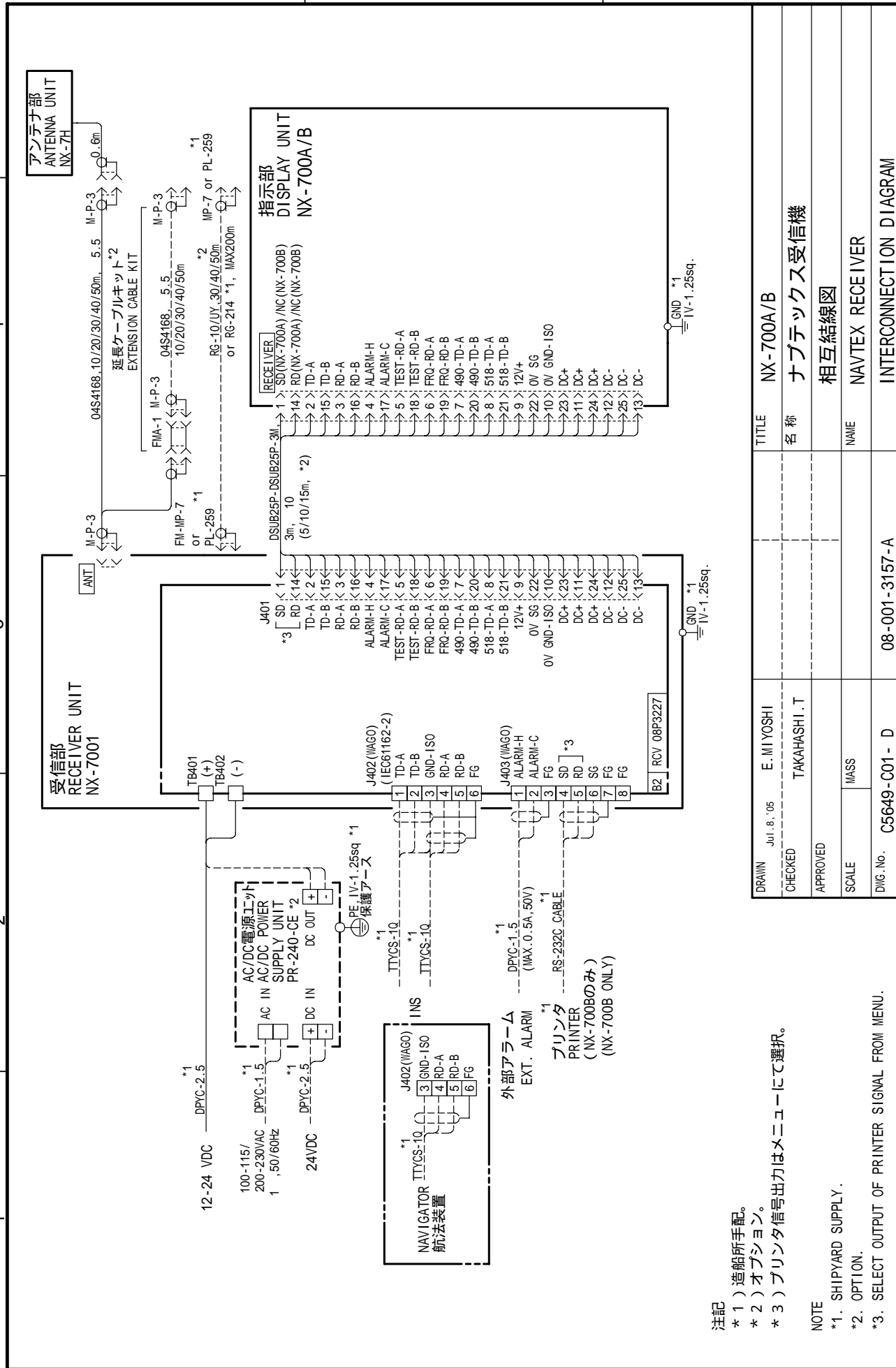

**注記**

- \*1) 造船所手配。
- \*2) オプション。
- \*3) プリント信号出力はメニューにて選択。

**NOTE**

- \*1. SHIPYARD SUPPLY.
- \*2. OPTION.
- \*3. SELECT OUTPUT OF PRINTER SIGNAL FROM MENU.

DRAWN	Jul. 8, '05	E. MIYOSHI	TITLE	NX-700A/B
CHECKED		TAKAHASHI, T	名称	ナビテックス受信機
APPROVED			相互結線図	
SCALE		1/25	NAME	NAVTEX RECEIVER
DIAG. No.	C5649-C01-D	08-001-3157-A	INTERCONNECTION DIAGRAM	



A

B

C

D

S - 2

A

B

C

D

S - 3

A

B

C

D

D

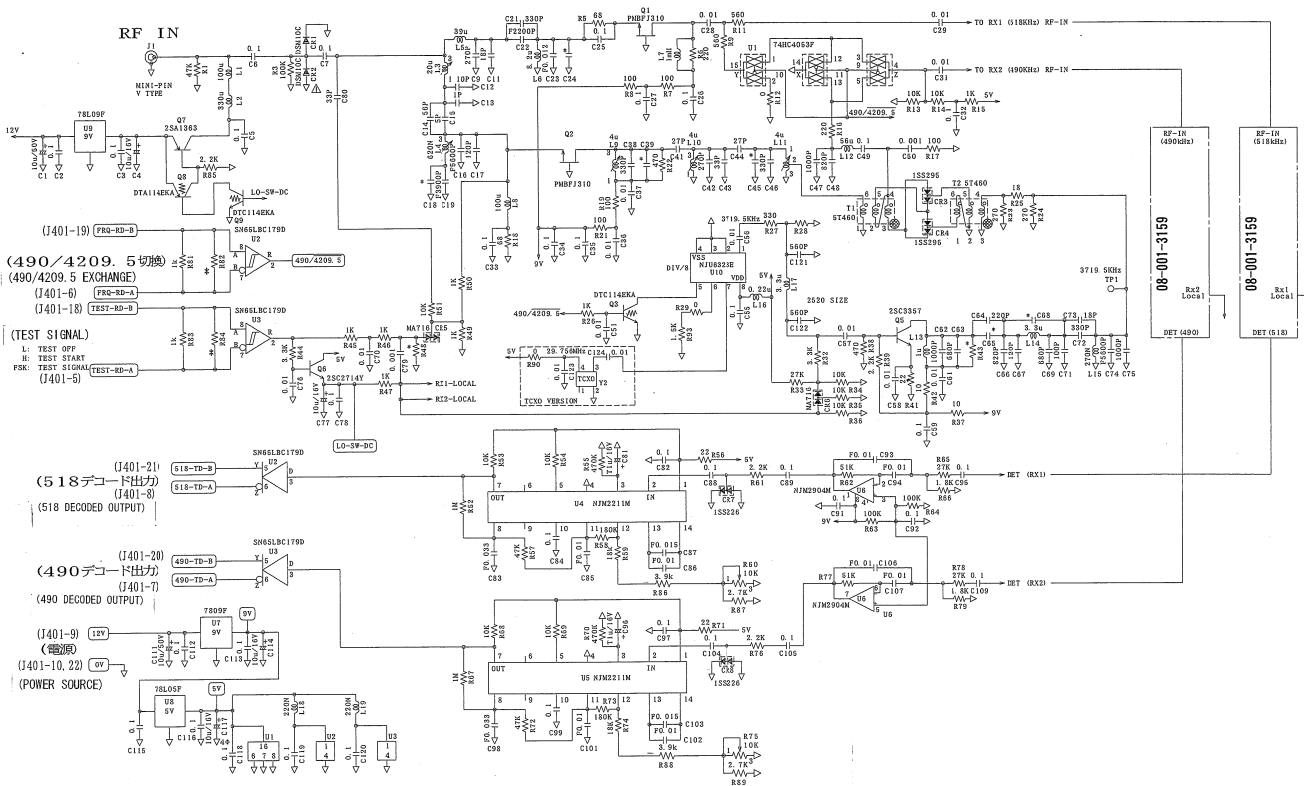

\*: PATTERN ONLY  
 C10/C18/C20/C24/C30/C39/C40/C45/C60/C65/C68/C90/C100/C108/C110  
 Q4  
 R4/R10/R20/R28/R30/R31/R40/R43/R48/R80/R82/R84  
 TP1

DRAWN 05/08/24 T. YAMASAKI	TYPE 08P3227 (1/2)
CHECKED S. S. T. Akawa	名称 RCV基板
APPROVED A. S. S. Akawa	回路図
SCALE MASS	NAME RCV PCB
Dwg No. C5649-K05- A	MODEL NX-7001
REF. No. 08-001-3158-3	BLOCK No.
	SCHMATIC DIAGRAM

**FURUNO ELECTRIC CO., LTD.**



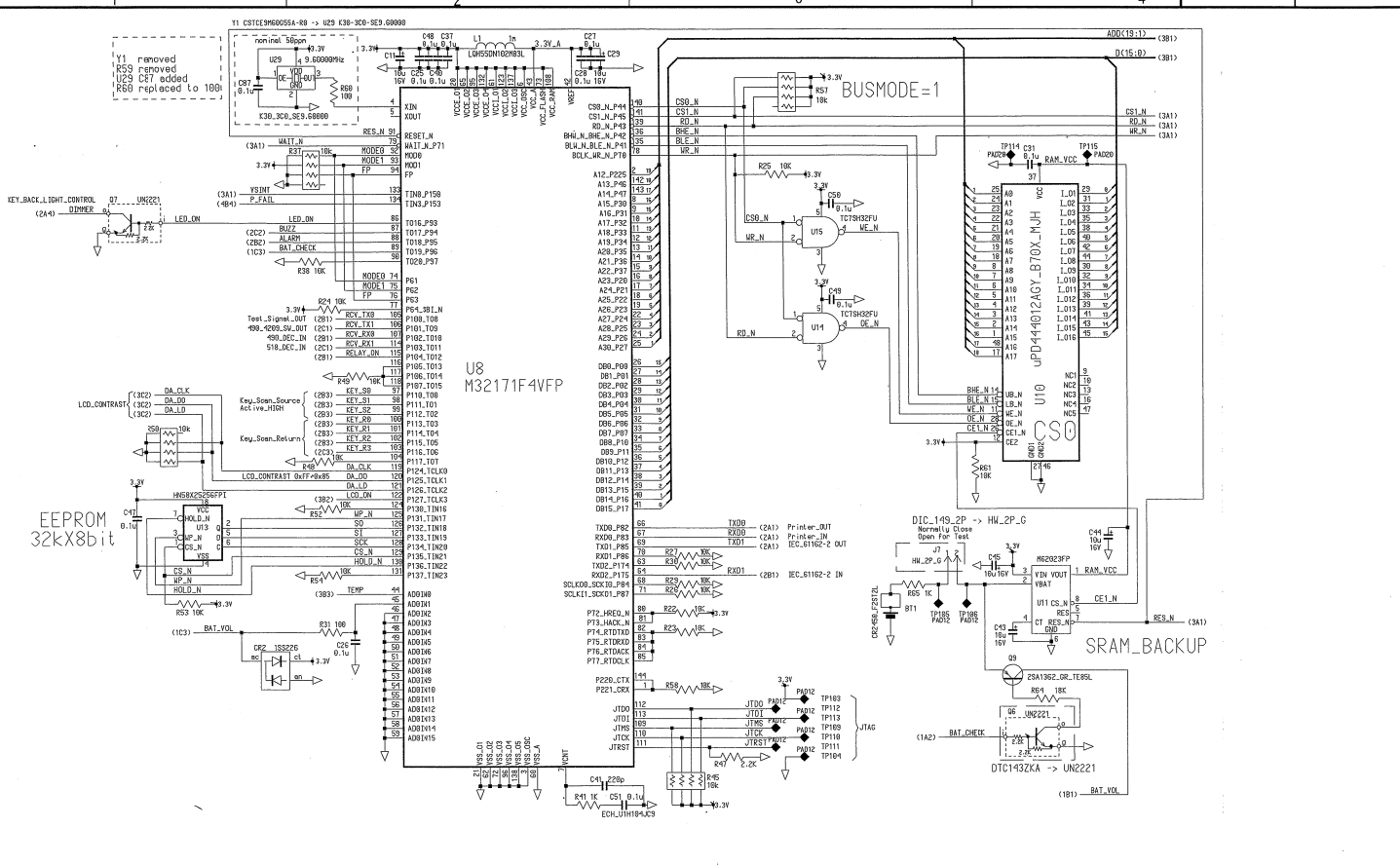

DRAWN 05/08/24 T. YAMASAKI	TYPE O8P3225 (1/4)
CHECKED 05/25/05 T. YAMASAKI	名称 CPU基板
APPROVED 05/25/05 H. ITOYAMA	NX-7001 MODEL
SCALE MASS	BLOCK No. NAME CPU PCB
Dwg No. C5649-K07- A	REF. No. 08-001-3153-3
SCHEMATIC DIAGRAM	

FURUNO ELECTRIC CO., LTD.

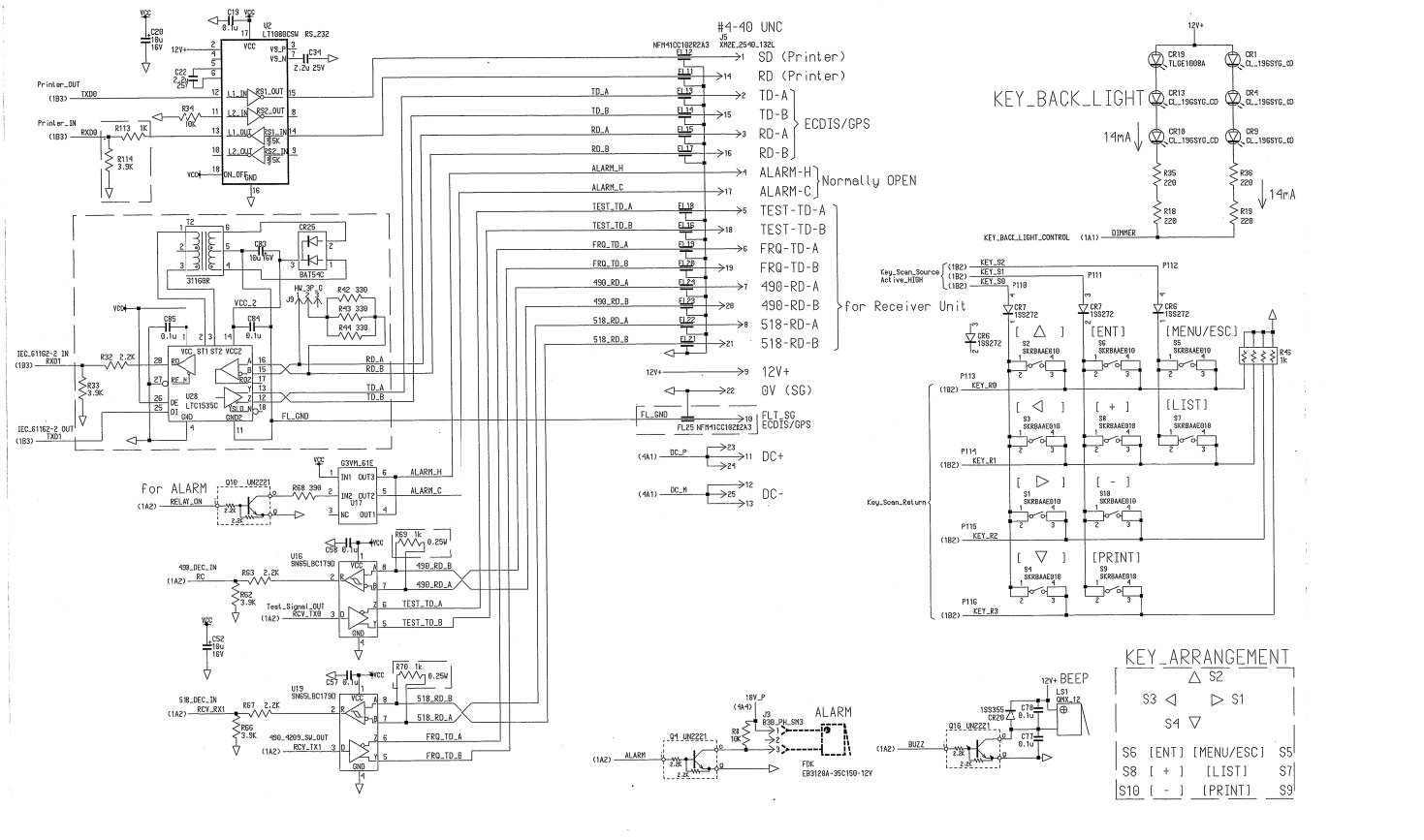

DRAWN 05/08/24 I. YAMASAKI	TYPE 08P3225 (2/4)
CHECKED S. J. O. O. O.	名称 CPU基板
APPROVED Aug 26 '05 N. Nishiyama	回路図
SCALE MASS	MODEL NX-7001
Dwg No. C5649-K08- A	BLOCK No.
REF. No. 08-001-3154-3	NAME CPU PCB
	SCHEMATIC DIAGRAM

**FURUNO ELECTRIC CO., LTD.**

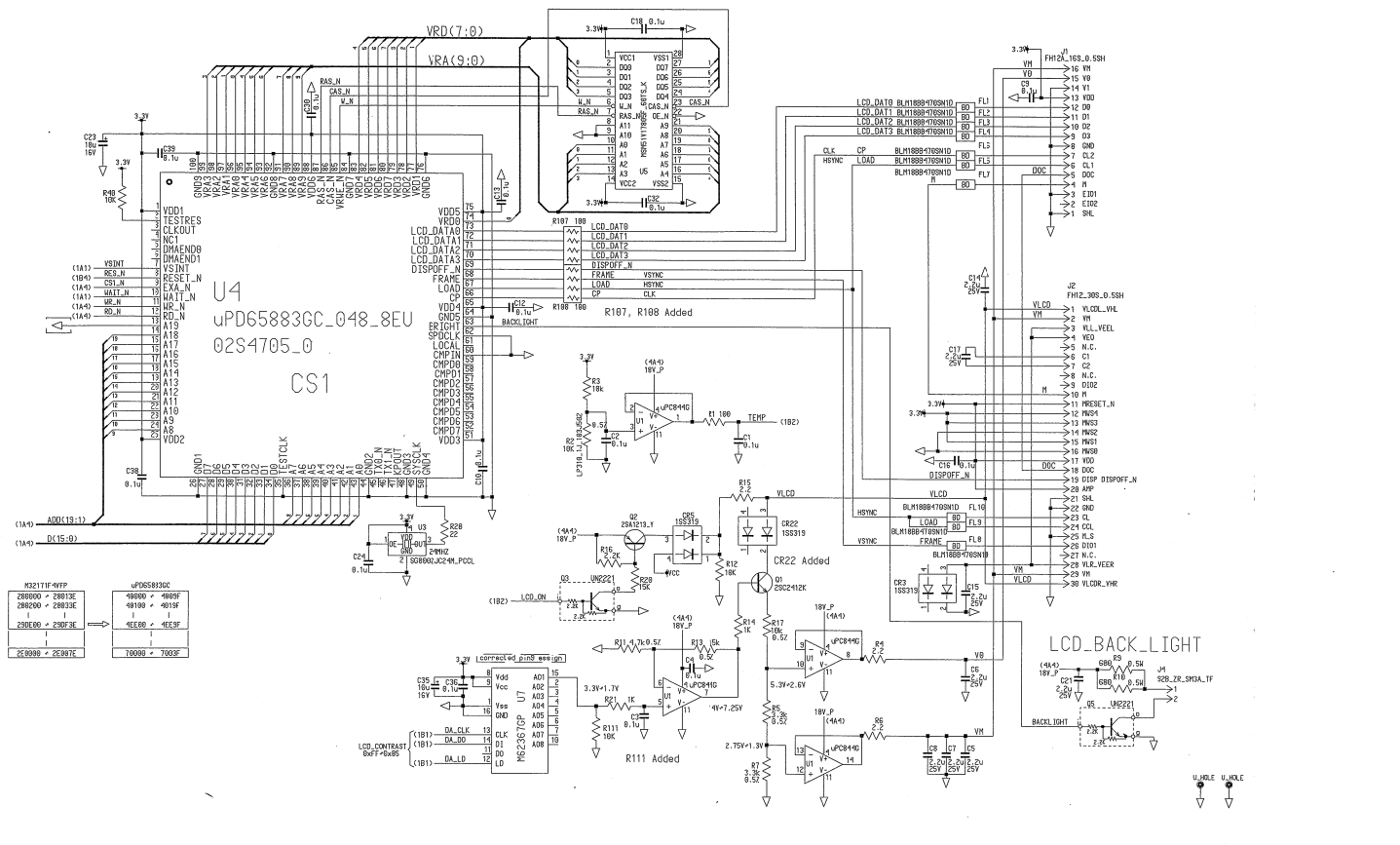

DRAWN 05/09/24 T. YAMASAKI	TYPE 08P3225 (3/4)
CHECKED A. Saito	名称 CPU基板
APPROVED A. Saito	回路図
SCALE 1:1	MODEL NX-7001
Dwg No. C5649-K09-A	BLOCK No.
REF. No. 08-001-3155-1	NAME CPU PCB
	SCHMATIC DIAGRAM

FURUNO ELECTRIC CO., LTD.



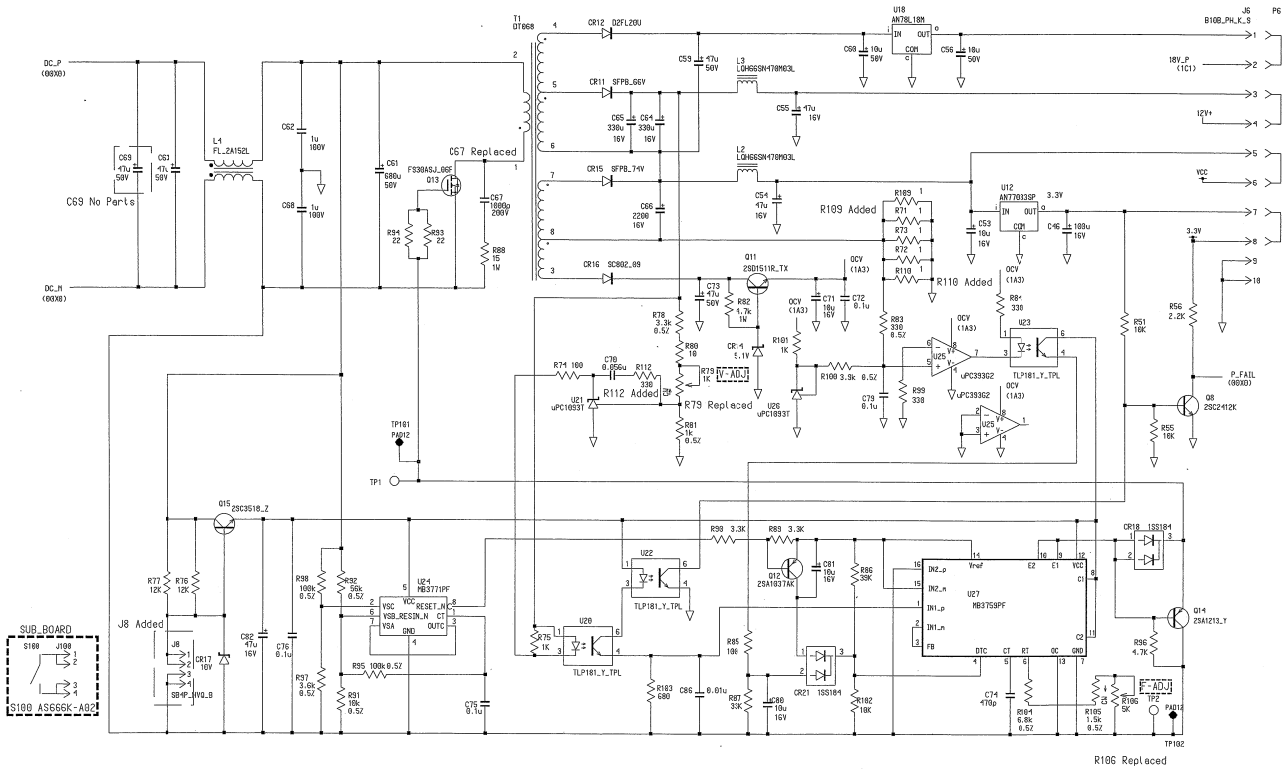

DRAWN 05/08/24 T. YAMASAKI	TYPE 08P3225 (4/4)
CHECKED <i>T. Takano</i>	名称 CPU基板
APPROVED <i>M. Nagata</i>	回路図
SCALE MASS	MODEL NX-7001
Dwg No. C5649-K10- A	BLOCK No.
REF. No. 08-001-3156-3	NAME CPU PCB
	SCHEMATIC DIAGRAM

FURUNO ELECTRIC CO., LTD.





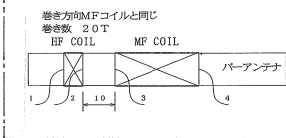
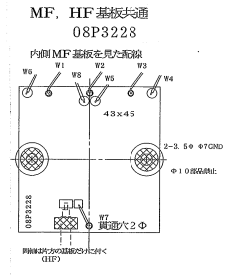
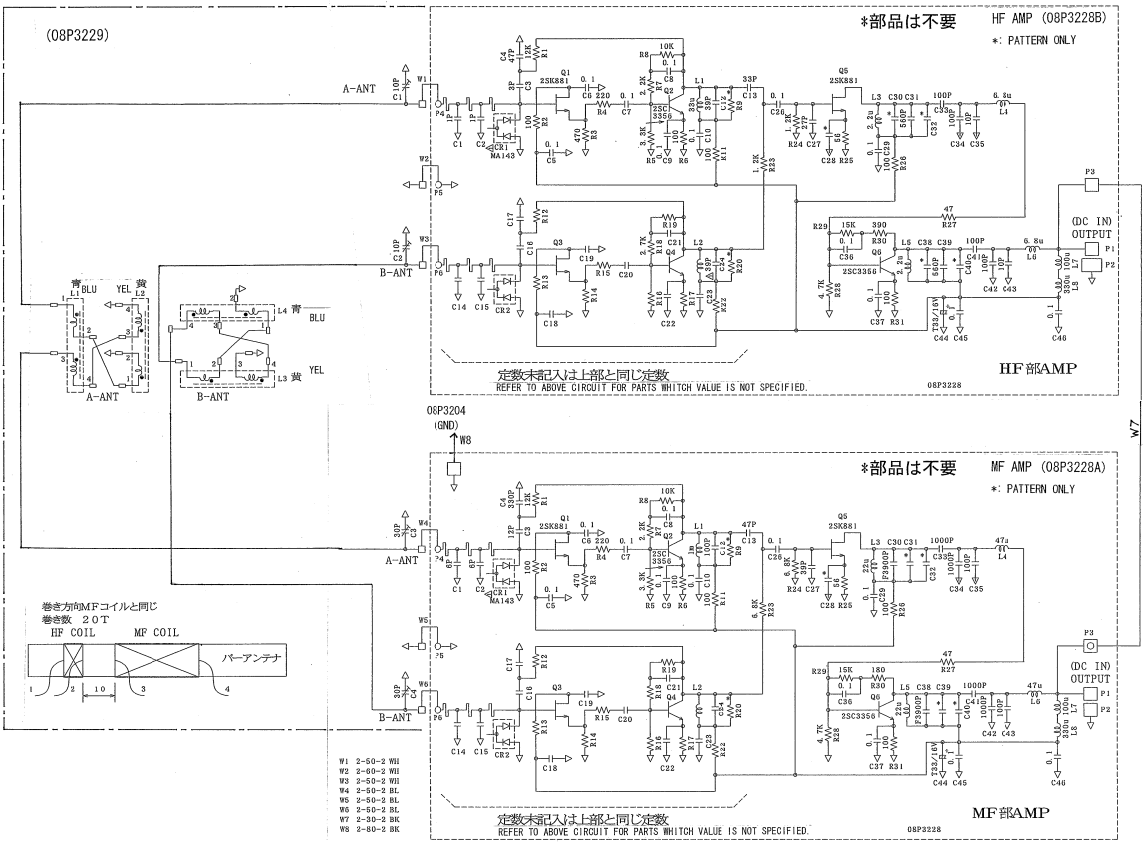

- W1 2-80-2 WH
- W2 2-80-2 WH
- W3 2-80-2 WH
- W4 2-80-2 BL
- W5 2-80-2 BL
- W6 2-80-2 BL
- W7 2-80-2 BK
- W8 2-80-2 BK

DRAWN	05/08/24 T. YAMASAKI	TYPE	NX-7H
CHECKED	<i>Approved T. Takano</i>	名称	アンテナ部
APPROVED	<i>Approved H. Nagashiki</i>	回路図	
SCALE	MASS	MODEL	NX-700A/B
Dwg No.	C5649-K03- A	BLOCK No.	
		NAME	ANTENNA UNIT
			SCHEMATIC DIAGRAM
		REF. No.	08-001-3152-1



