

Date

Jan. 30, 2019

**Released**

# X band Magnetron

## Model No. M1475A

**Copyright© 2019  
New Japan Radio Co., Ltd.  
Microwave Division**

-Notice of Proprietary Information-

This document and its contents are proprietary to New Japan Radio Co., Ltd.  
This publication and its contents may not be reproduced or distributed for any other purpose  
without the written permission of New Japan Radio Co., Ltd.  
Those specifications listed in this document are subject to change at any time, without notice.

New Japan Radio Co., Ltd.  
Microwave Division

Title:

Datasheet of M1475A

Reference No.:

DS-M1475A

Rev.:

02E

Sheet:

1/3

## ■ GENERAL DESCRIPTION

M1475A is designed for the magnetron of X band radar system. The frequency range is fixed <9345~9405MHz> and the peak output power is 25kW.



## ■ ELECTRICAL CHARACTERISTICS

PARAMETERS	MINIMUM	TYPICAL	MAXIMUM	UNITS
Heater voltage (note 1)	5.7	6.3	6.9	V
Heater current	0.43	0.52	0.6	A
Preheat time	120	-	-	s
Peak anode voltage (note 2)	7.2	8.0	8.5	kV
Peak output power (note 2)	22.5	25.0	-	kW
Frequency (note 2)	9345	9375	9405	MHz

## ■ ABSOLUTE MAXIMUM RATINGS

These ratings cannot necessarily be used simultaneously and no individual ratings should be exceeded.

PARAMETERS	MINIMUM	MAXIMUM	UNITS
Peak anode current (note 3)	6.0	10.0	A
Peak anode power input	-	75	kW
Duty cycle	-	0.001	-
Pulse duration	0.05	1.2	μs
Rate of rise of voltage pulse	-	100	kV/μs
Anode temperature	-	110	°C
VSWR at the output coupler	-	1.5 : 1	-

### Notes

1. With no anode input power. For average pulse input powers greater than 25 watts, the heater voltage must be reduced within 3 seconds after applied high voltage according to the following schedule:

$$\text{Heater Voltage: } E_f = 6.3 \sqrt{1 - \frac{P_i}{100}} \text{ [V]}$$

$$\text{Mean input power (Pi) = Anode current} \times \text{Anode voltage} \times \text{Duty cycle (W)}$$

2. Measured at peak anode current 8.0A.

\* Above Specifications are subject to change without notice.

- Any overshoot of the anode current is not acceptable. The impedance of this magnetron is the same as current magnetron excluding the transient impedance. This means that the additional reactance should be required for adjustment the anode current wave form, if this magnetron will be installed into the similar modulator circuit as before.

## OUTLINE

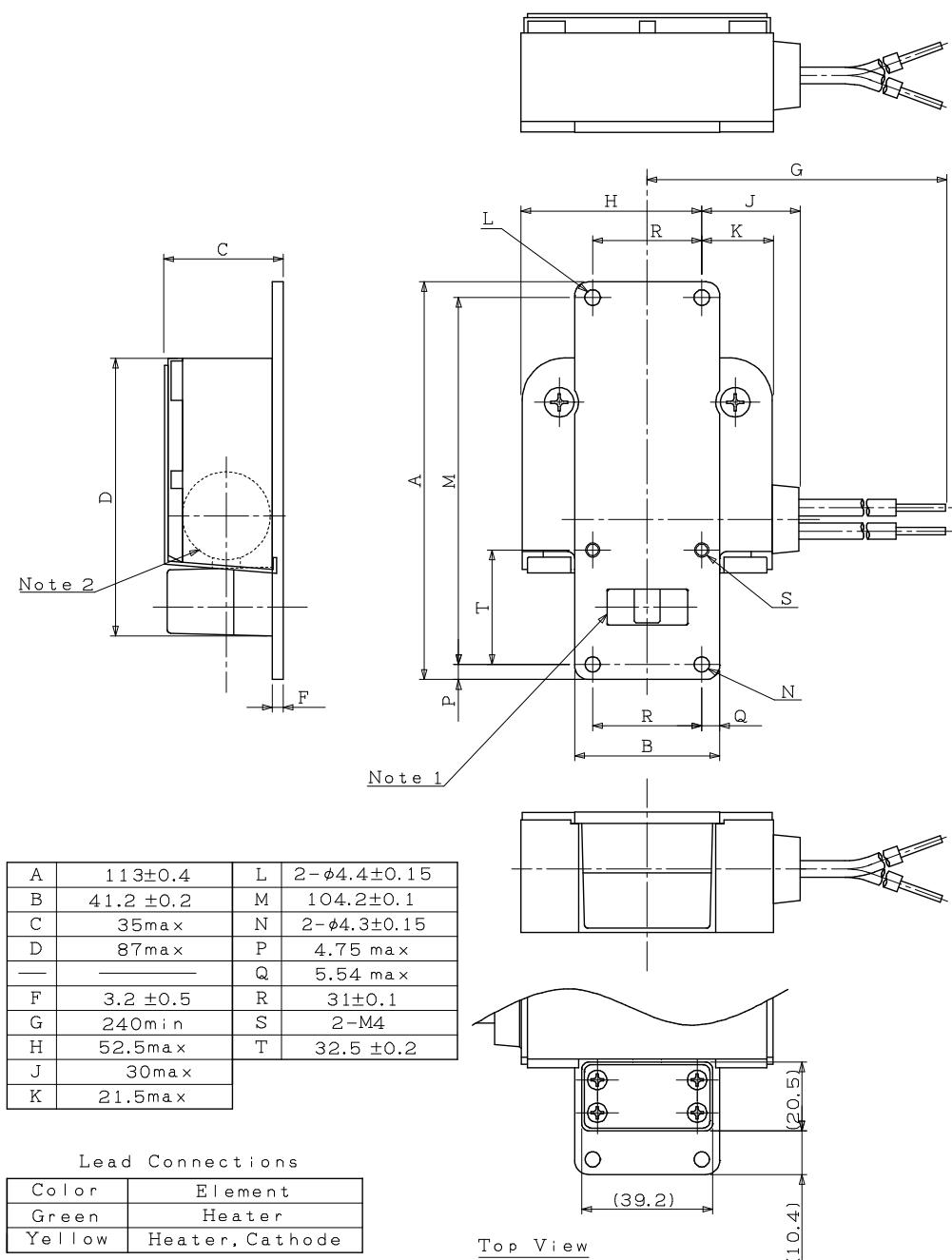

Note 1: The position of the waveguide and fixing holes will be such that the valve operates into coupler type UG-40 B/U.  
 Note 2: Anode temperature measured at this point.

(Dimensions are expressed in "mm".)

\* Above Specifications are subject to change without notice.

